Masters Theses

Student Theses and Dissertations

1966

An investigation of failure patterns of layered specimens loaded in uniaxial compression

Narendra Y. B. Choudary

Follow this and additional works at: https://scholarsmine.mst.edu/masters_theses

 Part of the [Mining Engineering Commons](#)

Department:

Recommended Citation

Choudary, Narendra Y. B., "An investigation of failure patterns of layered specimens loaded in uniaxial compression" (1966). *Masters Theses*. 2947.
https://scholarsmine.mst.edu/masters_theses/2947

This thesis is brought to you by Scholars' Mine, a service of the Curtis Laws Wilson Library at Missouri University of Science and Technology. This work is protected by U. S. Copyright Law. Unauthorized use including reproduction for redistribution requires the permission of the copyright holder. For more information, please contact scholarsmine@mst.edu.

AN INVESTIGATION OF FAILURE PATTERNS OF LAYERED
SPECIMENS LOADED IN UNIAXIAL COMPRESSION

by

NARENDRA CHOUDARY, Y. B.

A

THESIS

submitted to the faculty of

THE UNIVERSITY OF MISSOURI AT ROLLA

in partial fulfillment of the requirements for the

Degree of

MASTER OF SCIENCE IN MINING ENGINEERING

Rolla, Missouri

1966

Approved by

James J. Scott (advisor) Ronald R. Rollins
Ernest H. Spohn John B. Hester

123735

ABSTRACT

Uniaxial compressive strength for two and three-layered specimens was obtained with different thicknesses of layers and also for different length to diameter ratios. The fracture and failure pattern was studied. Shear and extension fractures were observed in the layers. Geometry and end conditions of the specimen had a great influence in the failure and fracture pattern.

The uniaxial compressive strength of a layered specimen was found to be lower than the weighted average strength and either low or high when compared to the arithmetic average strength, depending on the ratio of the heights of the layers. The compressive strength of a layered specimen increases as the ratio of length to diameter decreases. The influence of the number of non-cohesive interfaces on compressive strength has also been observed. Suggestions are made for calculating the compressive strength of a layered pillar.

ACKNOWLEDGEMENTS

The author wishes to express his appreciation to Dr. James J. Scott for his continual encouragement and advice, without which this investigation would not have been possible. Special thanks are extended to Dr. Charles J. Haas for reading the manuscript.

TABLE OF CONTENTS

	PAGE
ABSTRACT	ii
ACKNOWLEDGEMENTS	iii
TABLE OF CONTENTS	iv
LIST OF FIGURES	vi
LIST OF TABLES	ix
SYMBOLS AND DEFINITIONS	x
CHAPTER	
I. INTRODUCTION	1
A. General	1
B. Literature Survey	2
II. EXPERIMENTAL PROCEDURE	7
A. Properties of Materials	7
B. Preparation of Specimens	10
C. Testing Procedure	10
III. EXPERIMENTAL RESULTS	16
IV. DISCUSSION OF EXPERIMENTAL RESULTS	22
A. Fracture Analysis	22
1. General	22
2. Fracture Pattern	22
3. Wedge Action	24
4. Differential Expansion	24

5. Influence of Geometry	28
6. Fracture and Failure Pattern in Three Layers ...	29
B. Influence of Bed Thickness on Uniaxial Compressive Strength	31
C. Variation of Uniaxial Compressive Strength with a Change in Bed Thickness in Relation to the Diameter of the Specimen	37
D. Influence of Three Layers on Uniaxial Compressive Strength	45
E. Influence of Length to Diameter Ratio on Uniaxial Compressive Strength	47
F. Two Layers Versus Three Layers	47
V. CONCLUSIONS AND RECOMMENDATIONS	50
A. Conclusions	50
B. Recommendations	51
BIBLIOGRAPHY	52
APPENDIX	55

LIST OF FIGURES

<u>Figures</u>	<u>Page</u>
1. Distribution of Vertical Principal Stress Inside a Cylinder Compressed Between Rough Rigid Planes (after Filon)	4
2. Comparison of Vertical Principal Stress Distribution According to Filon and Pickett (after Pickett)	4
3. Stress Versus Strain for a Specimen of Limestone	8
4. Stress Versus Strain for a Specimen of Dolomite	9
5. Stress Versus Strain for a Specimen of Sandstone	11
6. Method Used for Measuring Strain	12
7. Circuit Diagram of Sonic Equipment	14
8. Photograph Showing the Fracture Pattern in a Limestone Specimen	20
9. Photograph Showing the Fracture Pattern in a Dolomite Specimen	20
10. Photograph Showing the Fracture Pattern in a Sandstone Specimen	21
11. Photograph Showing the Fracture Pattern in a Two-Layered ($h_1/h_2 = 1$) Specimen of Limestone/Dolomite	23
12. Diagram Showing the Formation of Fractures Due to the Influence of Geometry as Illustrated in Figure 11	23
13. Photograph Showing the Fracture Pattern in a Two-Layered ($h_1/h_2 = 0.33$) Specimen of Limestone/Dolomite	25
14. Photograph Showing the Fracture Pattern in a Two-Layered ($h_1/h_2 = 0.19$) Specimen of Limestone/Sandstone.....	26
15. Photograph Showing the Fracture Pattern in a Two-Layered ($h_1/h_2 = 0.11$) Specimen of Limestone/Dolomite	26
16. Photograph Showing the Fracture Pattern in a Two-Layered ($h_1/h_2 = 0.33$) Specimen of Sandstone/Dolomite	27

<u>Figures</u>	<u>Page</u>
17. Photograph Showing the Fracture Pattern in a Two-Layered ($h_1/h_2 = 3.0$) Specimen of Limestone/Dolomite	30
18. Photograph Showing the Fracture Pattern in a Three-Layered Specimen Having $s:l:d = 1:1:1$ and with a 2:1 Length to Diameter Ratio	30
19. Photograph Showing the Fracture Pattern in a Three-Layered Specimen Having $s:l:d = 0.44:1:1$ and With an 2:1 Length to Diameter Ratio	32
20. Photograph Showing the Fracture Pattern in a Three-Layered Specimen Having $s:l:d = 1:1:1$ and With an 0.65:1 Length to Diameter Ratio	32
21. Photograph Showing the Fracture Pattern in a Three-Layered Specimen Having $s:l:d = 1:0.44:1$ and With an 2:1 Length to Diameter Ratio	33
22. Photograph Showing the Fracture Pattern in a Three-Layered Specimen Having $s:l:d = 1:0.35:1$ and With an 2:1 Length to Diameter Ratio	33
23. Compressive Strength Versus Ratio of h_1/h_2 (Sandstone/ Dolomite)	34
24. Compressive Strength Versus Ratio of h_1/h_2 (Limestone/ Dolomite)	35
25. Compressive Strength Versus Ratio of h_1/h_2 (Limestone/ Sandstone)	36
26. The Difference Between Weighted Average and Test Value Versus Ratio of h_1/h_2	38
27. The Difference Between Arithmetic Average and Test Value Versus Ratio of h_1/h_2	39
28. Compressive Strength Versus Ratio of h_1/D (Sandstone/ Dolomite)	40
29. Compressive Strength Versus Ratio of h_1/D (Limestone/ Dolomite)	41
30. Compressive Strength Versus Ratio of h_1/D (Limestone/ Sandstone)	42
31. The Difference Between Weighted Average and Test Value Versus Ratio of h_1/D	43

<u>Figures</u>	<u>Page</u>
32. The Difference Between Arithmetic Average and Test Value Versus Ratio of h_1/D	44
33. Compressive Strength Versus Ratio of Length to Diameter for Three-Layered Specimens	48

LIST OF TABLES

<u>Tables</u>	<u>Page</u>
1. Physical Properties of Different Rock Types	17
2. Variation of Compressive Strength with a Change in h_1/h_2 Ratio for Different Combinations of Rock Types with Constant Length	18
3. Variation of Compressive Strength with a Change in Layer Thickness and the Ratio of Length to Diameter in Three-Layered Specimens	19
4. Variation of Compressive Strength with a Change in Thickness of Each Layer in psi	46

SYMBOLS AND DEFINITIONS

D Diameter of the layered specimen

L Total length of the layered specimen

h Height of individual layer

d Dolomite

l Limestone

s Sandstone

h_1/h_2 Ratio of heights of two formations in which
 h_1 is always the height of low strength member and
 h_2 is always the height of high strength member.

h_1/D Ratio of the height of a layer to the diameter of the
layered specimen in which h_1 is always the height of a
low strength member in a layered specimen.

STRENGTH RATIO: This is the ratio of compressive strengths of
the high strength member to that of the low strength mem-
ber. Compressive strength of each member is obtained
from a 2:1 length to diameter ratio specimen, subjected
to uniaxial compression.

WEIGHTED AVERAGE: (compressive strength)

$$\frac{\sum_{i=1}^n \sigma_i l_i}{\sum_{i=1}^n l_i} = \frac{\sum_{i=1}^n \sigma_i l_i}{L}$$

Where l_i are weights and σ_i are the 'n' numbers and 'L' is the total length of the specimen. In this investigation l is the height of each layer and σ_i is the compressive strength of each layer, based on a 2:1 length to diameter ratio specimen subjected to an uniaxial compression test, where the ends of the specimen are in direct contact with the steel platens.

ARITHMETIC AVERAGE: (compressive strength)

In the above equation if l_i are all equal it reduces to arithmetic average.

TEST VALUE: This always refers to the uniaxial compressive strength of a layered specimen as obtained in the laboratory.

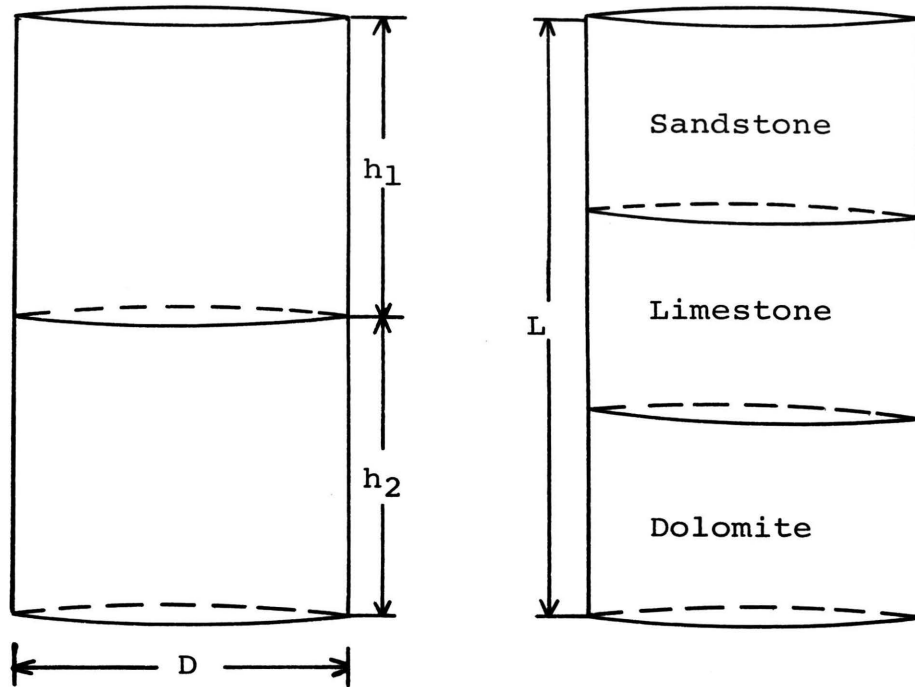

Figure Showing the Dimensions of Specimens

I. INTRODUCTION

Mining engineers are interested in the safest and most efficient design for underground mine and construction openings. Safety of employees, protection of equipment, low-cost mining with optimum recovery from the deposit all depend on the ability of engineers to design and excavate underground openings. One of the important criteria in the design of underground openings is pillar strength. For a massive deposit, pillar strength can be approximated from laboratory tests using ASTM standard procedures. In sedimentary bedded deposits the determination of the compressive strength of a pillar poses some problems. The United States Bureau of Mines¹³ has suggested using arithmetic average of the compressive strengths of various strata as the basic design criteria. The author has in this investigation examined the effects of layered strata on ultimate pillar strength.

To shorten the time required for this investigation, work has been confined to some of the essential aspects of pillar strength using two and three sedimentary layers. The compressive strength of the layered specimen is correlated with both the arithmetic and weighted averages of the individual layers. The compressive strength of the layered specimen has also been correlated with the compressive strength of the least strength layer. An attempt has been made to analyse the failure and fractures, in relation to the geometry of the specimen. A few three-layered specimens were tested to determine

the effect of length to diameter ratio on compressive strength.

B. Literature Survey

The term compressive strength related to brittle rock generally implies the maximum load per unit cross-sectional area sustained by a prepared sample of the rock before collapse in a testing machine.⁶

Standard compressive strength test procedures proposed by the United States Bureau of Mines and the American Society for Testing Materials require that the ends of the rock specimen be placed in direct contact with the loading platens of the test machine. Using this procedure one might suppose that a uniform compressive stress would exist through the sample and that the horizontal stress would be equal to zero. However, it has been found that a uniform stress condition very rarely exists.

Filon⁷ and Pickett¹⁴ have done pioneering analytical work with different boundary conditions for stress distribution in a specimen loaded with uniform uniaxial load. Filon made a theoretical analysis of cylinders subjected to uniaxial compressive stress in which the ends were restrained i.e. no expansion at the edges. The theoretical principle stress σ_z distribution for a specimen of length to diameter ratio of approximately one is shown in Figure 1. It is seen from the figure that across the end planes the stress is a maximum at the edges $r = a$, $z = \pm b$, and a minimum at the center $r = 0$, $z = \pm b$. Cylindrical coordinates r, θ, z are used, the cylinder having a height '2b' and a radius 'a'. Pickett assumed the same boundary conditions as Filon, except that he replaced Filon's assumption "no expansion

at the edges" by "the ends do not expand at any point." This gives rise to constant radial and tangential stresses σ_r ⁽⁶⁾ and σ_θ respectively across the ends such that $\sigma_r = \sigma_\theta = \frac{\nu}{1-\nu} \sigma_z$ where ν is Poisson's ratio. This solution introduces a stress discontinuity at the edges $r = a$, $z = \pm b$. Comparing these two, the normal stress distribution differs considerably at the end. However they tend to the same value toward the outer edges of the cylinder as seen in Figure 2, the agreement is fairly close at the center $z = 0$. The stress distribution given by the two solutions is similar near the center two-thirds of the cylinder. The "non-uniform" region extending approximately one sixth of the diameter vertically into the specimen from the end planes should also be approximately constant in vertical extent and independent of the height of the specimen. Thus, for a 2:1 length to diameter ratio, the specimen will be under almost uniform vertical stress over the middle five-sixths of its length.

A considerable amount of work has been done on capping materials for concrete test specimens. The effect of the capping is to reduce the end constraint, thus giving a more uniform stress distribution in the specimen. Capping materials are placed on both ends of the concrete test specimens. Considerable work has been done on capping materials by G. E. Troxill¹⁶, T. B. Kennedy, G. Werner¹⁷, and others, and some experimental work has been done using photoelasticity by A. J. Durelli and W. M. Murray¹⁶.

In discussing Troxill's work on "The Effect of Capping and End Conditions Before Capping Upon the Compressive Strength and Concrete Test Cylinders" W. M. Murray points out the following factors which

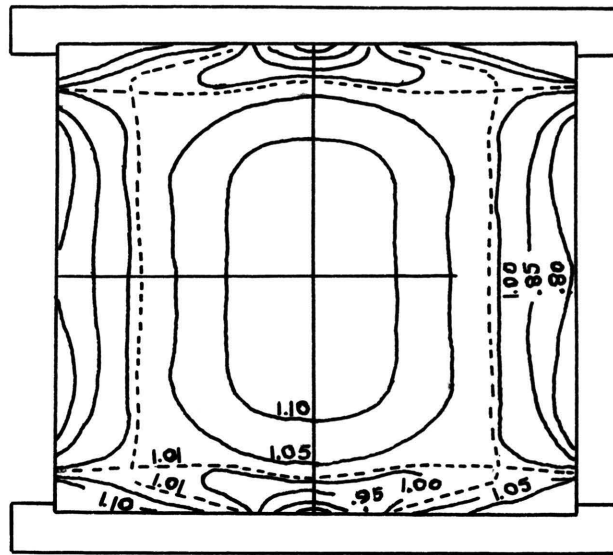

Figure 1. Distribution of Vertical Principal Stress Inside a Cylinder Compressed Between Rough Rigid Planes (after Filon)

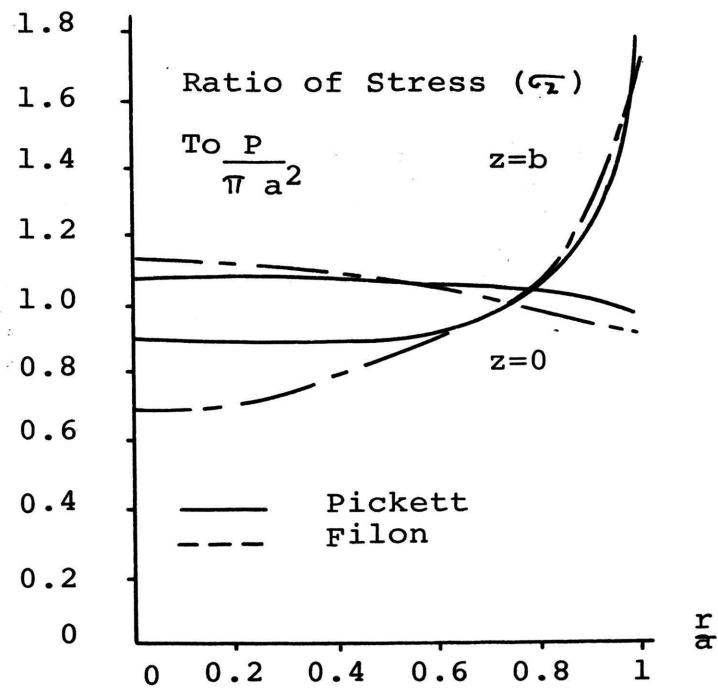

Figure 2. Comparison of Vertical Principal Stress Distribution According to Filon&Pickett (after Pickett)

he has also observed using photoelasticity.

1. That the most desirable and representative conditions can be attained with a capping material that is as strong as or stronger than the material of the test specimen.
2. That the capping material should have approximately the same modulus of elasticity and Poisson's ratio as the material under test.

When capping material flows or expands laterally to a greater extent than does the test specimen, lateral tension is produced and is sometimes so severe that failure takes place from tension at a lower load than would normally be expected. This has been most noticeable on a granite specimen where sheet lead has been placed between the steel platens of the testing machine and the granite specimen¹⁶. The granite failed at 2/3 of the stress normally expected.

A. J. Durrelli points out that by using cardboard as a capping material on a Bakelite specimen in his photoelastic investigation, there is a thickness which produces the optimum distribution of stress. Above and below this thickness the concentration of stress increases¹⁶. The United States Bureau of Mines found the measured strength of a granite to be reduced by approximately 10 per cent when using capping materials, and do not advocate capping in their proposed standardized test procedures⁵.

The United States Bureau of Mines has done some work concerning the compressive strength of a layered specimen which was not published.

A brief mention has been made in U. S. B. M. Bulletin No. 587, which states, "unpublished laboratory tests have shown that the strength of pillars composed of different strata of rock usually is more nearly equal to the average strength of the various strata of rock rather than to the strength of the weakest stratum."¹³ Only limited work has been done on the effect of layered strata on ultimate strength of pillars.

II. EXPERIMENTAL PROCEDURE

Sedimentary formations were considered in this investigation as they are most often encountered in bedded deposits. The results obtained may be extended to other formations with some restrictions as to the nature of their contact surfaces and the type of fractures which develop. Rocks of varying compressive strengths and Young's moduli were selected for conducting the tests. Samples were prepared from BX cores of 12 in. in length obtained from South Texas Stone Company, Houston, Texas. Cylindrical cores were used as it simplified the geometry of the specimen for analysis.

A. Properties of Materials

1. Indiana limestone. This rock has been used extensively by many investigators for test purposes. It is a medium to fine grained limestone. The grain sizes are very nearly uniform. The rock is compact, exhibits low porosity, and is, for all practical purposes, homogeneous. The stress strain curve in Figure 3 is seen to be linear, and very little residual strain remained in the specimen after unloading, indicating that the rock is quite elastic.

2. Kasota dolomite. This is a medium to fine grained rock. The distribution of grain sizes is uneven, making it less homogeneous when compared to the other two rock types. The matrix in this rock gives it a high degree of hardness and compactness. The stress-strain curve shown in Figure 4 is linear. This rock also exhibits

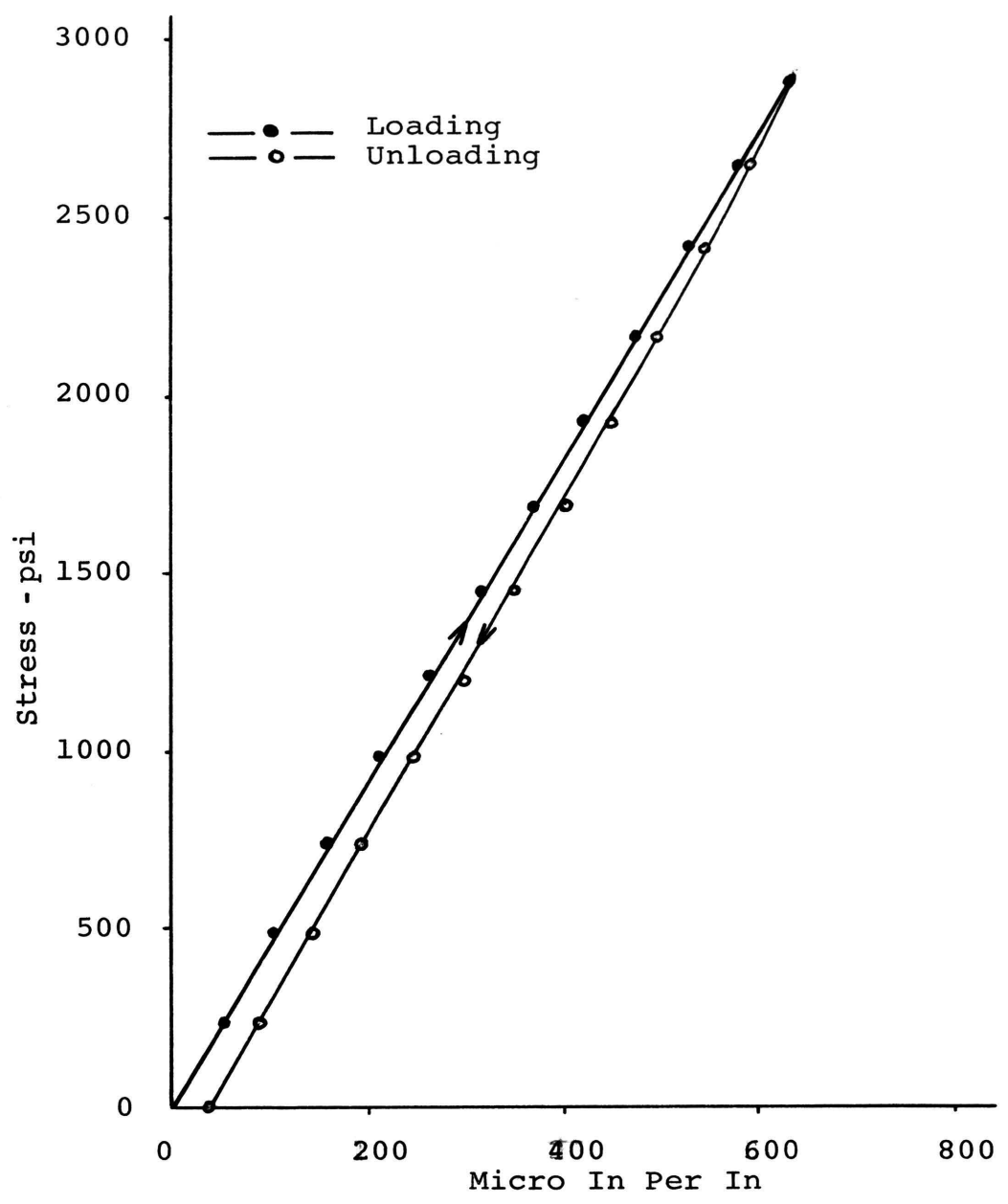

Figure 3. Stress Versus Strain for a Specimen of Limestone

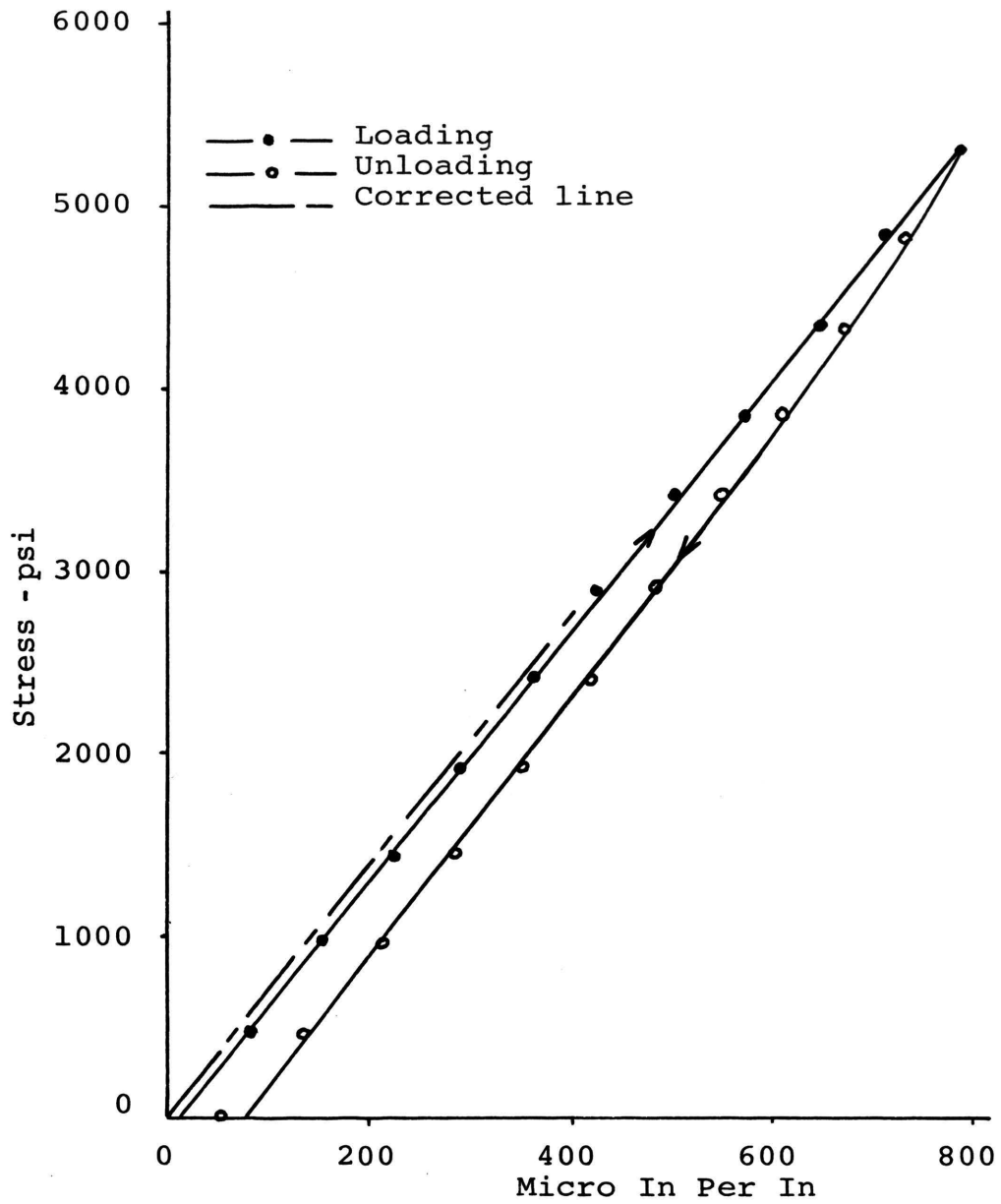

Figure 4. Stress Versus Strain for a Specimen of Dolomite

very little residual strain in the specimen during the unloading cycle.

3. Berea sandstone. This is a medium to fine grained sandstone. The distribution of grain sizes is very nearly even and it is also quite homogeneous. This sandstone has a high porosity when compared to the other two rock types. The stress strain curve shown in Figure 5 is linear up to 2000 psi; above 2000 psi the slope increases slightly. During the unloading cycle, large residual strains were observed in the specimen. There was some permanent set due to its porous nature.

B. Preparation of Specimen

Cylinders and discs were cut with a diamond saw from cores to prescribed dimensions. The procedure for the preparation of test specimens was adopted from the results of tests conducted by the U. S. Bureau of Mines⁵.

C. Testing Procedure

Testing of the specimens was carried out in the following manner:

1. For each rock type three 2:1 length to diameter ratio specimens were tested to determine the compressive strength and Young's modulus. Two 1/4 in. long Dentronics foil electrical resistance gages were attached to opposite sides of a single specimen to obtain an average strain (Figure 6 a). Strain was measured by a Hathaway strain indicator as shown in Figure 6 b. The specimens were loaded to approximately one half of their compressive strength to measure the strain for the determination of Young's modulus. The Young's modulus determined in this manner was then compared to the value ob-

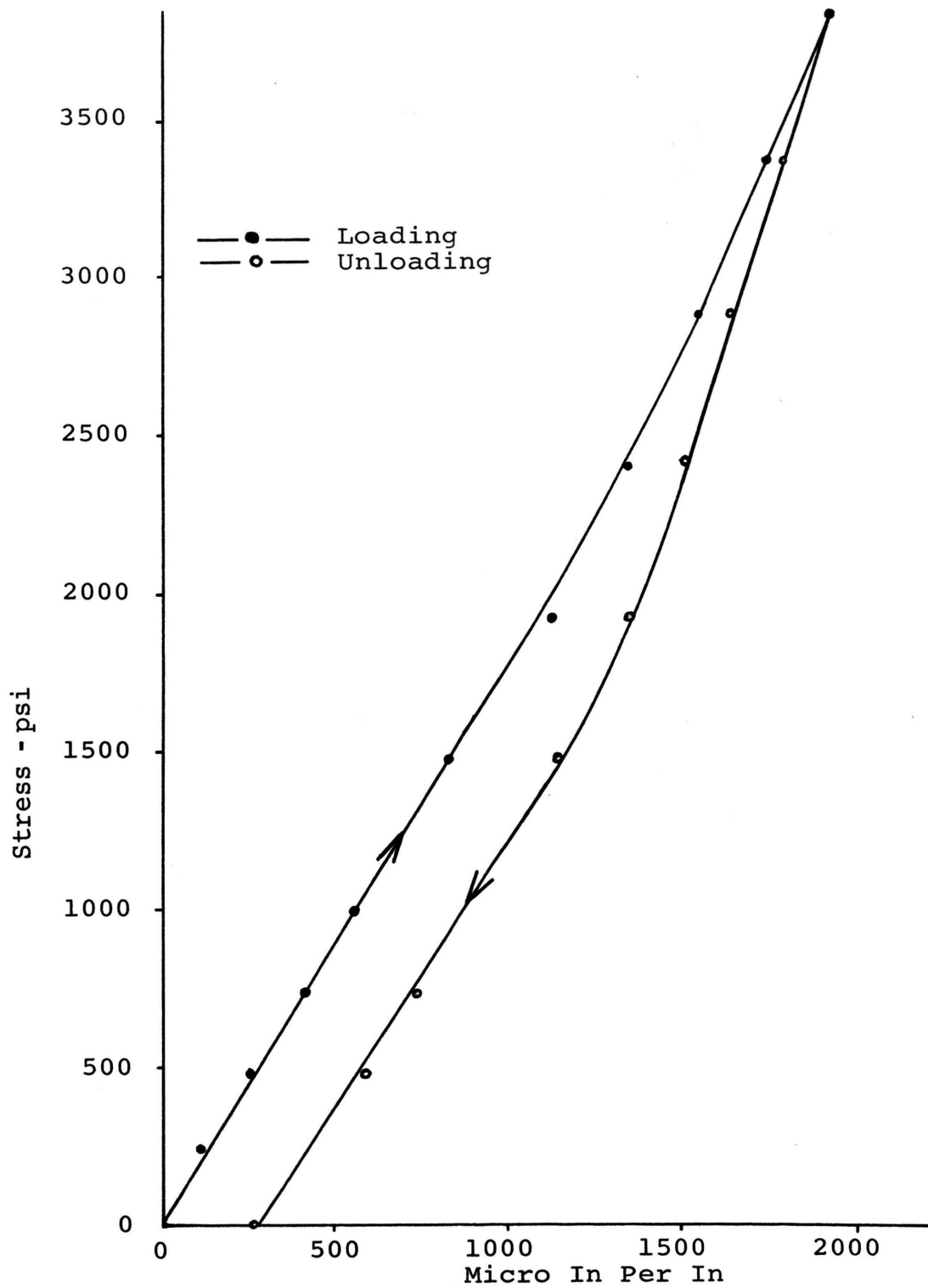
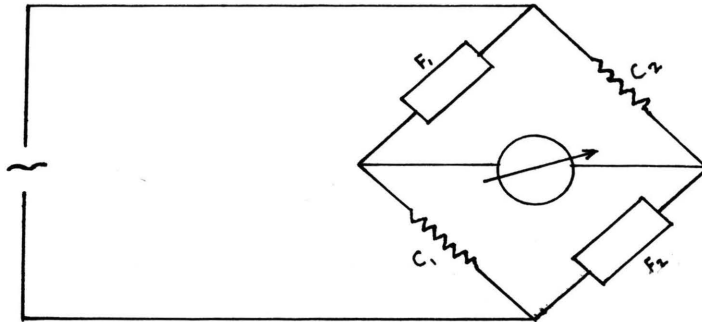

Figure 5. Stress Versus Strain for a Specimen of Sandstone



$F_1 F_2$ = Foil Gages

$C_1 C_2$ = Compensating Gages

a. The Modified Wheatstone Circuit

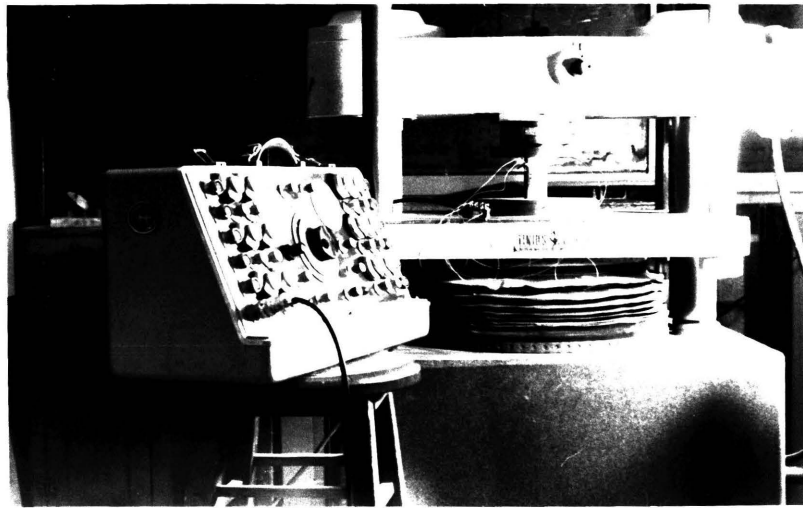

b. Equipment used

Figure 6. Method Used for Measuring Strain

tained by the sonic pulse method. Equipment for the sonic tests included a pulse generator, an oscilloscope and piezoelectric transducer as shown in Figure 7. The values obtained for Young's modulus by these two methods compared favorably.

2. Tests were run on two-layered specimens, keeping the overall length constant, and changing the h_1/h_2 ratios. From previous studies of the variation of compressive strength with the length-to-diameter ratio, it was decided to keep the total length-to-diameter ratio constant at 2:1. The diameter for all cores was 1.625 in., thus the length was approximately 3.25 in.

The combinations tested were limestone-dolomite, sandstone-dolomite and limestone-sandstone. The ratios of h_1/h_2 tested ranged from 9.85 to 0.04 for the various combinations.

3. Specimens composed of three layers or strata were also tested. Again an overall length-to-diameter ratio of 2:1 was maintained. The thickness of each layer was varied to determine how the test values compared with the two-layered specimens. In these tests the sequence of layers was kept constant with sandstone at the top, limestone in the middle and dolomite at the bottom. The weak strength stratum was always placed in the middle to better ascertain how the weak member effects the overall compressive strength of the specimen.

4. The ratio of thicknesses of sandstone, limestone and dolomite was kept constant at 1:1:1 and the overall length of the specimen was changed. Altogether four samples with length-to-diameter

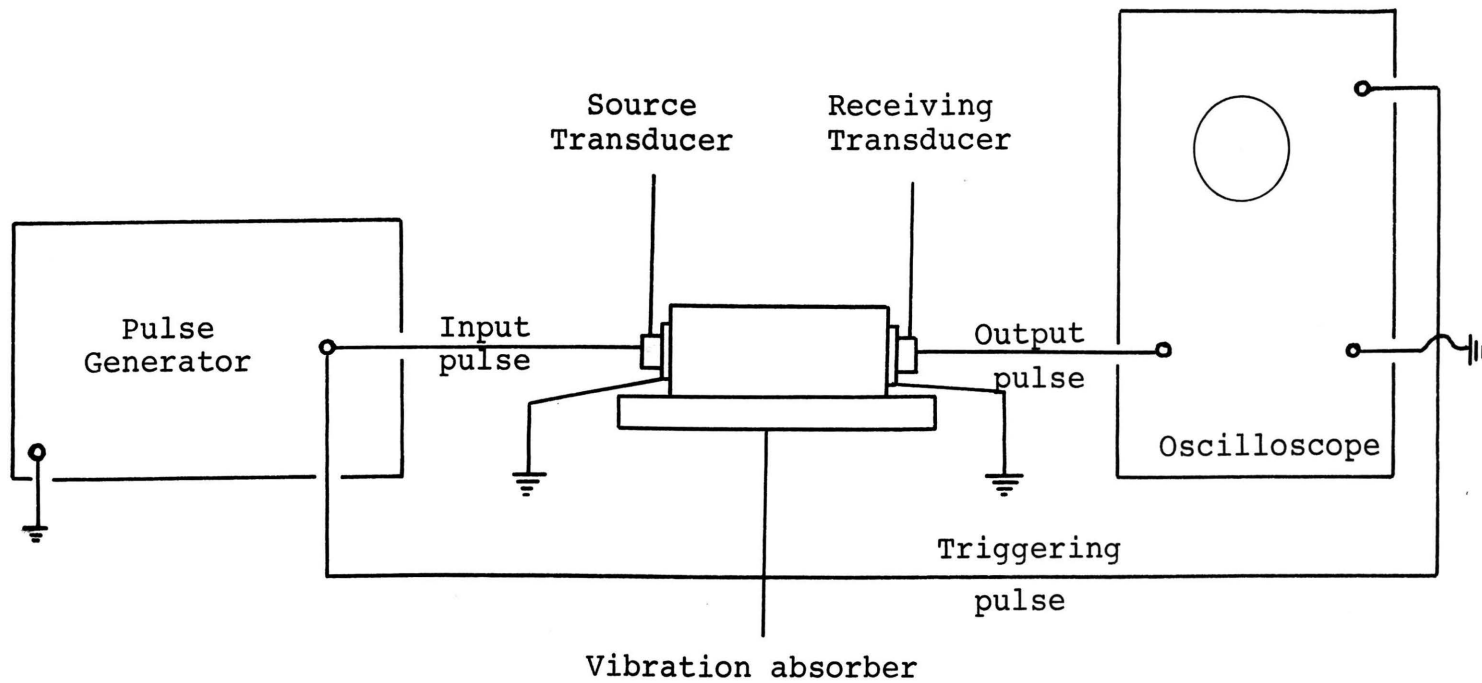

Figure 7. Circuit Diagram of Sonic Equipment

ratios of 2.0, 1.6, 1.1, and 0.65 were tested. In these tests the layers were arranged in the same sequence as described in step 3. The thickness of layer corresponding to the above ratios are 1.1, 0.85, 0.6 and 0.35 in. respectively.

Before testing, the specimen surfaces were ground and polished as described in sample preparation. These layers were arranged one above the other with non-cohesive interfaces, i.e., no glue or any other material was placed between the surfaces of contact. Specimens were tested in a Tinius Olsen Testing machine having a capacity of 120,000 pounds with four scales for different loading ranges. Specimens were placed in direct contact with the steel platens. No other material was used or placed between the steel platens and the ends of the specimen.

III. EXPERIMENTAL RESULTS

The experimental results obtained for individual two-layered and three-layered specimens are tabulated in Tables 1, 2 and 3 respectively. All three rock types failed with shear fractures as shown in Figures 8, 9 and 10 when tested independently.

ROCK TYPE	COMPRESSIVE STRENGTH L/D=2 psi.	TENSILE STRENGTH BRAZIL TEST psi.	YOUNG'S MODULUS $\times 10^6$ psi.	YOUNG'S MODULUS SONIC PULSE $\times 10^6$ psi.
Limestone	6500	440	4.50	4.02
Sandstone	8400	360	1.66	1.66
Dolomite	11700	620	6.95	6.40

Table 1. Physical Properties of
Different Rock Types

SPECI- MEN NO.	h_1/h_2	COMPRESSIVE STRENGTH IN psi		
		STRENGTH RATIOS		
		1.89	1.44	1.28
1	9.83	8100	7800	8350
2	7.00	7850	7650	7150
3	5.40	5650	8200	5800
4	2.95	5600	8250	6300
5	1.00	5400	7180	6000
6	0.32	8000	10200	6300
7	0.17	7500	9450	5950
8	0.14	11800	12800	7400
9	0.11	8900	10600	6830
10	0.04	12300	---	6800

Table 2. Variation of Compressive Strength
With a Change in h_1/h_2 Ratio for Different
Combinations of Rock Types With Constant Length

SPECI- MEN NO.	FORMATION RATIOS			L/D RATIO	COMPRESSIVE STRENGTH psi.
	s	1	d		
1	1	1	1	2.00	7120
2	1	.44	1	2.00	7840
3	1	.35	1	2.00	7120
4	.44	1	1	2.00	7330
5	1	1	.44	2.00	6720
6	1	1	1	1.60	6850
7	1	1	1	1.10	7700
8	1	1	1	0.65	8850

Table 3. Variation of Compressive Strength With a Change
in Layer Thickness and the Ratio of Length to
Diameter in Three-Layered Specimens



Figure 8. Photograph Showing The Fracture Pattern in a Limestone Specimen

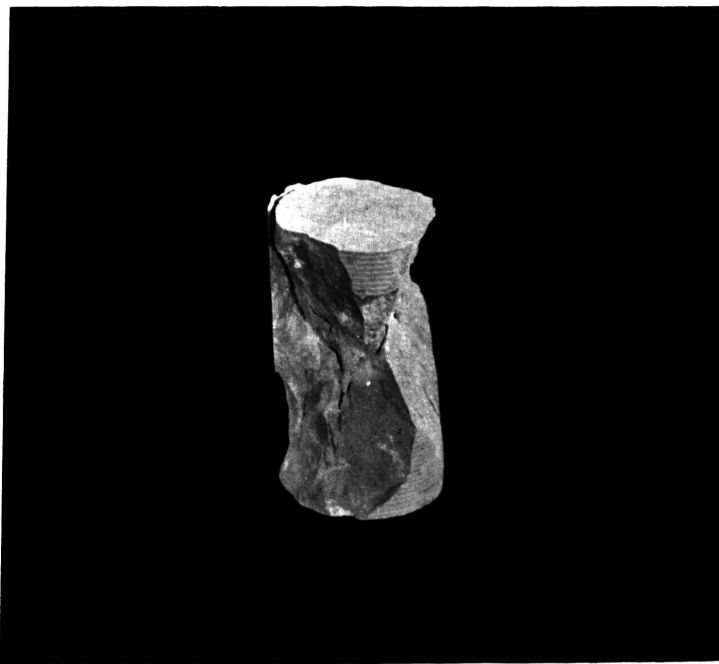

Figure 9. Photograph Showing The Fracture Pattern in a Dolomite Specimen



Figure 10. Photograph Showing The Fracture Pattern in a Sandstone Specimen

IV. DISCUSSION OF EXPERIMENTAL RESULTS

A. Fracture Analysis

1. General. When testing rocks in compression two types of fractures are observed, shear fractures and tension fractures. The two fracture systems are usually distinguishable. Shear fracture occurs when the shear stress exceeds the shear strength of the material. These fractures are inclined to the direction of compression at an angle less than 45 degrees. The surface of a shear fracture usually shows granulation and is commonly slickensided. Tension fractures occur parallel to the direction of compression. The fracture surface is generally clean cut across the material, with no evidence of granulation or slickensiding. In shear fractures, the deviation from the theoretical angle of 45 degrees is presumed to be due to internal friction.

2. Fracture Pattern: Two-Layered Specimen. A characteristic fracture pattern was observed in all the specimens having two layers. In a specimen with an h_1/h_2 (limestone/dolomite) ratio of one, (remembering that h_1 is always the height of low strength member and h_2 is always the height of high strength member) and with an over all length to diameter ratio of 2:1, the limestone failed with shear fractures, forming a shear cone as seen in Figure 11 and 12. This cone, with an area at the bottom less than the original specimen,

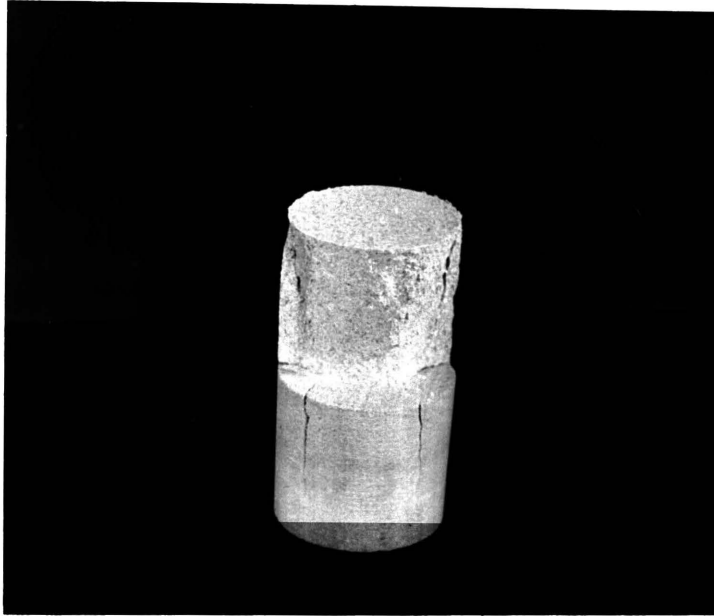

Figure 11. Photograph Showing the Fracture Pattern in a Two-Layered ($h_1/h_2=1$) Specimen of Limestone/Dolomite

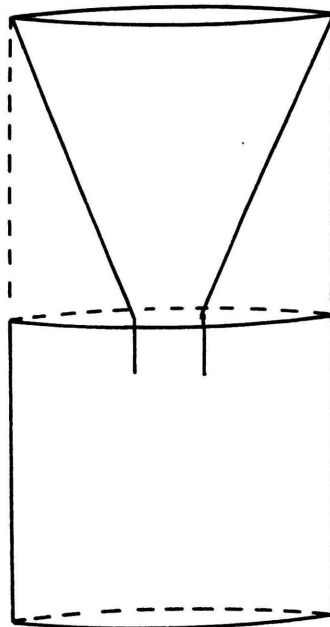

Figure 12. Diagram Showing the Formation of Fractures Due to the Influence of Geometry as Illustrated in Figure 11

was resting directly on dolomite. With this reduction in area of limestone at the contact surface, the stress increased significantly, exceeding the compressive strength of dolomite. At this stage the dolomite failed in tension with fractures running vertically and starting at the outer contact points of the original shear cone. (Figure 13 a, b.)

At lower h_1/h_2 ratios the fractures continued throughout the length of dolomite with clear cut faces, Figure 14 and 15. The reduced length and width of the fracture after some distance was probably due to the restraint at the end of the specimen. These fractures were observed in all the three combinations tested. The tension fractures formed in dolomite could be due to: 1) wedge action, or 2) differential expansion at contact surface of the two layers.

3. Wedge Action. It is very difficult to distinguish between wedge action and differential expansion in a fractured specimen with two layers, but in some specimens the wedge action is clearly indicated. In Figure 16 the h_1/h_2 ratio of sandstone to dolomite is 0.33, the surface beneath the cone is crushed and the propagation of cracks diminished after a short distance. It may be noted that this is not the case with a specimen having an h_1/h_2 ratio of 0.11, Figure 15. It may be concluded that the wedge action is predominant at higher h_1/h_2 ratios rather than at lower h_1/h_2 ratios. This statement is valid only when h_1/h_2 is less than 1.

4. Differential Expansion. For failure by differential expansion the compressive strength and Young's modulus play an important role.

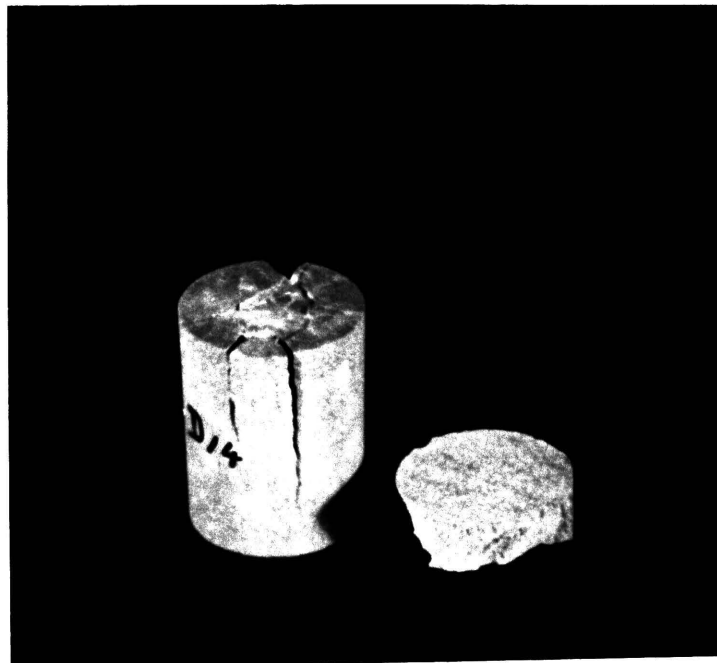

Figure 13. Photograph Showing the Fracture Pattern in a Two-Layered ($h_1/h_2=0.33$) Specimen of Limestone/Dolomite

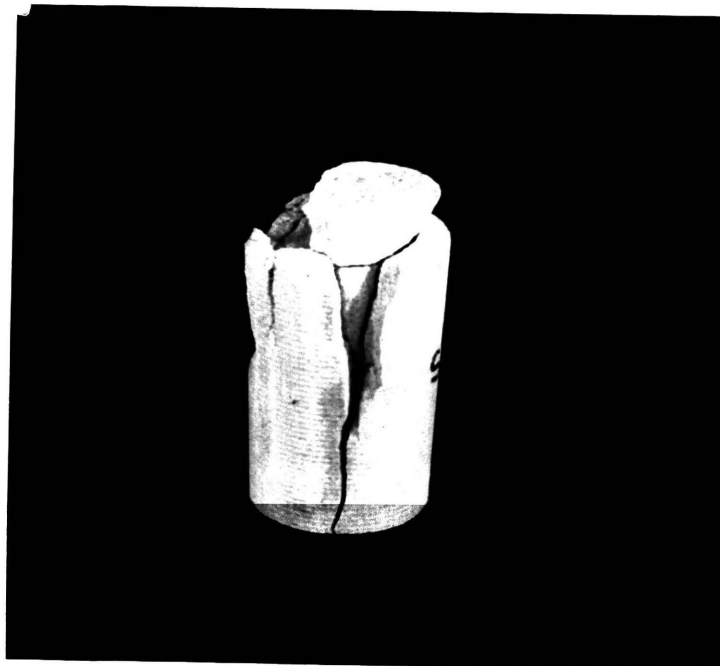

Figure 14. Photograph Showing the Fracture Pattern
in a Two-Layered ($h_1/h_2=0.19$) Specimen of
Limestone/Sandstone

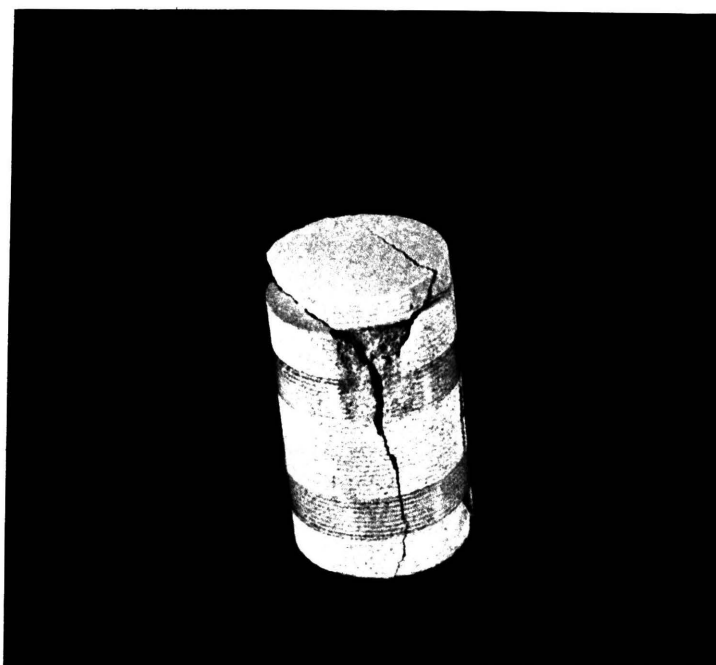

Figure 15. Photograph Showing the Fracture Pattern
in a Two-Layered ($h_1/h_2=0.11$) Specimen of
Limestone/Dolomite

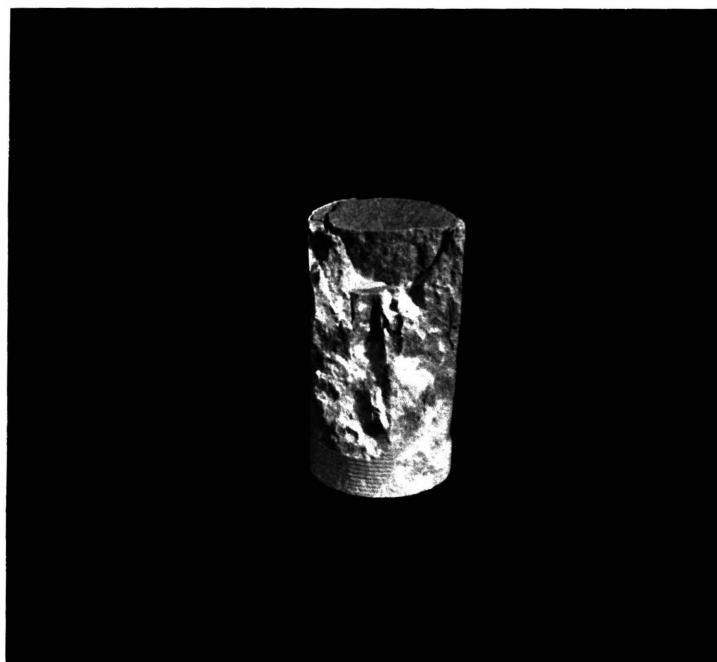

Figure 16. Photograph Showing the Fracture Pattern
in a Two-Layered ($h_1/h_2=0.33$) Specimen of
Sandstone/Dolomite

When a high strength and high Young's modulus rock is sandwiched between a low strength, low modulus rock, and subjected to uniaxial loading, the low modulus rock expands laterally to a greater extent than does the high modulus rock. The lateral extension can be so severe that failure takes place by tension.

In these experiments dolomite was in direct contact with steel platens on one side and with limestone on the other side. On one side the dolomite was affected by the differential expansion and on the other side it was restrained. At low stress, i.e. before the formation of shear cone, differential expansion may not be great enough to overcome the restrained end condition. After the formation of shear cone, the stress is higher at the contact surface and thus is able to overcome the restrained end condition.

5. Influence of Geometry. Even though it is believed that shear fractures formed first in limestone and that extension fractures formed later in dolomite, it appears that the formation of these fractures was almost simultaneous. As the ratio of limestone to dolomite thickness decreases, the layer of limestone reduces in thickness. The decrease in the thickness of the limestone layer gives rise to an increase in the area of the shear cone at the contact surface. At some particular thickness of limestone the stress at the contact surface after forming the shear cone is less than the compressive strength of dolomite. The dolomite failed. A specimen representing this condition is shown by the limestone-dolomite combination in Figure 15. The specimen failed at an applied stress of 8900 psi and the stress at the bottom of shear cone was approximately 10,000 psi.

This was calculated by measuring the diameter at the cone base. The same type of conditions have been observed in all three combinations.

Under steady state stress conditions the wedge action may not be a significant factor, but under a sudden change of stress at a contact point on the interface, its effect may be appreciable. This sudden change of stress will create high tangential forces at the contact surface. This affects the differential expansion which in turn causes the specimen to fracture violently. This was observed while testing the specimens.

For limestone to dolomite thickness ratios greater than one it has been observed that the limestone failed with shear fractures forming a shear cone as shown in Figure 17, where the top layer is dolomite and the bottom layer is limestone.

6. Fracture and Failure Pattern in Three Layers. Three-layered specimens have the same sequence of arrangement in all cases, sandstone at the top, limestone in the middle and dolomite at the bottom. In all specimens the sandstone failed with the formation of a shear cone as shown in Figure 18. The other two formations failed by vertical fractures starting at the outer contact points of the cone. At lower length-to-diameter ratios both sandstone and dolomite failed with the formation of shear cones due to high stresses involved as seen in Figure 19.

The compressive strength of sandstone at a length-to-diameter ratio of 2 is 8400 psi. The compressive strength of a rock (one layer) increases as the length-to-diameter ratio decreases. (Bureau of Mines⁵,



Figure 17. Photograph Showing the Fracture Pattern in a Two-Layered ($h_1/h_2=3.0$) Specimen of Limestone/Dolomite

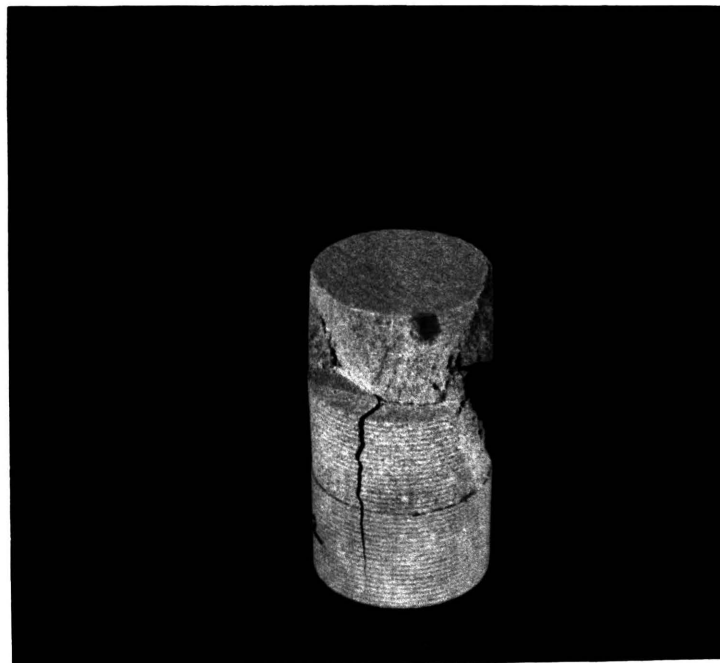

Figure 18. Photograph Showing the Fracture Pattern in a Three-Layered Specimen Having $s:l:d=1:1:1$ and With a 2:1 Length to Diameter Ratio

Hardy⁹.) Most of the three-layered specimens failed below 8000 psi even after reducing the thickness of layers. In all these specimens the sandstone failed with the formation of a shear cone. Thus, it appears that the formation of a shear cone in sandstone is aided by the tangential forces created by the differential expansion at the contact surface, thereby reducing the overall compressive strength.

Reducing or increasing the thickness of the weak strength member (limestone) did not greatly alter the fracture pattern as evidenced by the photographs in Figures 19, 21 and 22. However, increasing the thickness of the weak strength member reduced the overall strength.

B. Influence of Bed Thickness on Uniaxial Compressive Strength

The uniaxial compressive strength of a layered specimen was found to be a little lower than the strength of the weakest member where the proportion of low strength member exceeded the high strength member. As the proportion of high strength member was further increased, the compressive strength of the layered specimen increased, finally approaching the strength of the high strength member as seen in Figures 23 to 25 and 28 to 30. In a two-layered specimen the minimum compressive strength was obtained when the two beds were approximately equal in height. The difference between the test value and the strength of the weakest member increases as the difference between the compressive strengths of the two layers increases as seen in Figures 23 to 25.

The compressive strength of a layered specimen is always less than the weighted average of the strengths of the individual members, the difference being a maximum when both members are approximately equal in thickness. On either side of this the difference decreases

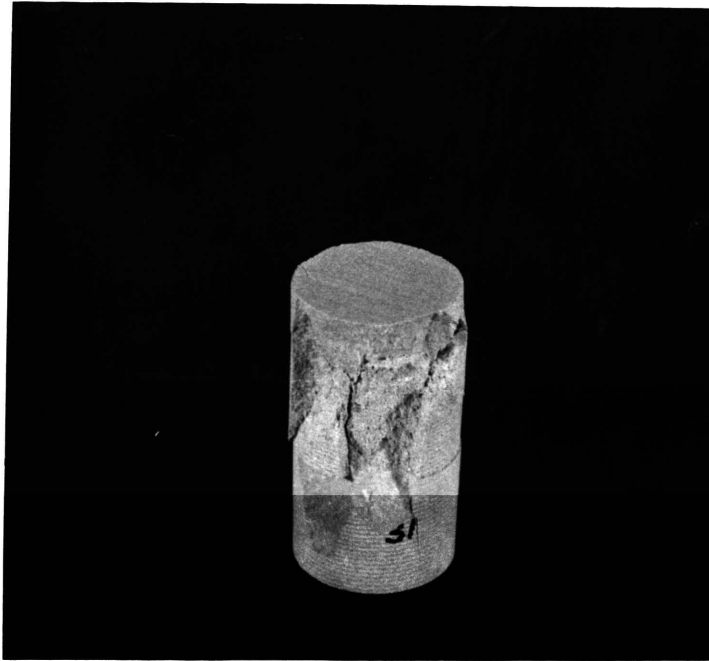

Figure 19. Photograph Showing the Fracture Pattern in a Three-Layered Specimen Having $s:l:d=0.44:1:1$ and With an 2:1 Length to Diameter Ratio

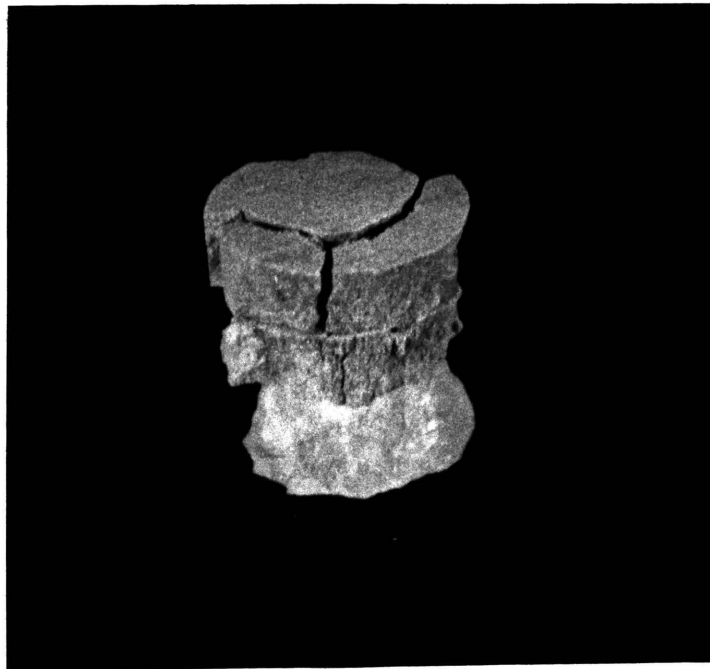

Figure 20. Photograph Showing the Fracture Pattern in a Three-Layered Specimen Having $s:l:d=1:1:1$ and With an 0.65:1 Length to Diameter Ratio



Figure 21. Photograph Showing the Fracture Pattern in a Three-Layered Specimen Having $s:l:d=1:0.44:1$ and With an 2:1 Length to Diameter Ratio

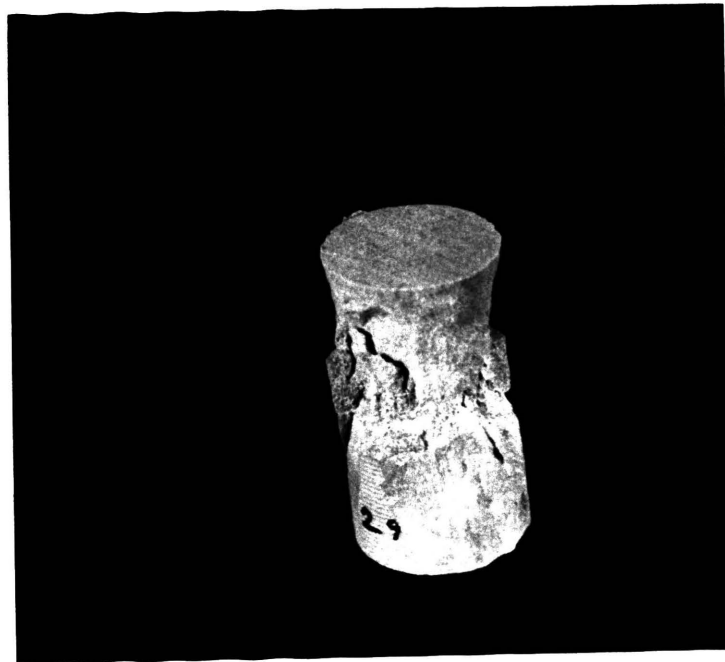

Figure 22. Photograph Showing the Fracture Pattern in a Three-Layered Specimen Having $s:l:d=1:0.35:1$ and With an 2:1 Length to Diameter Ratio

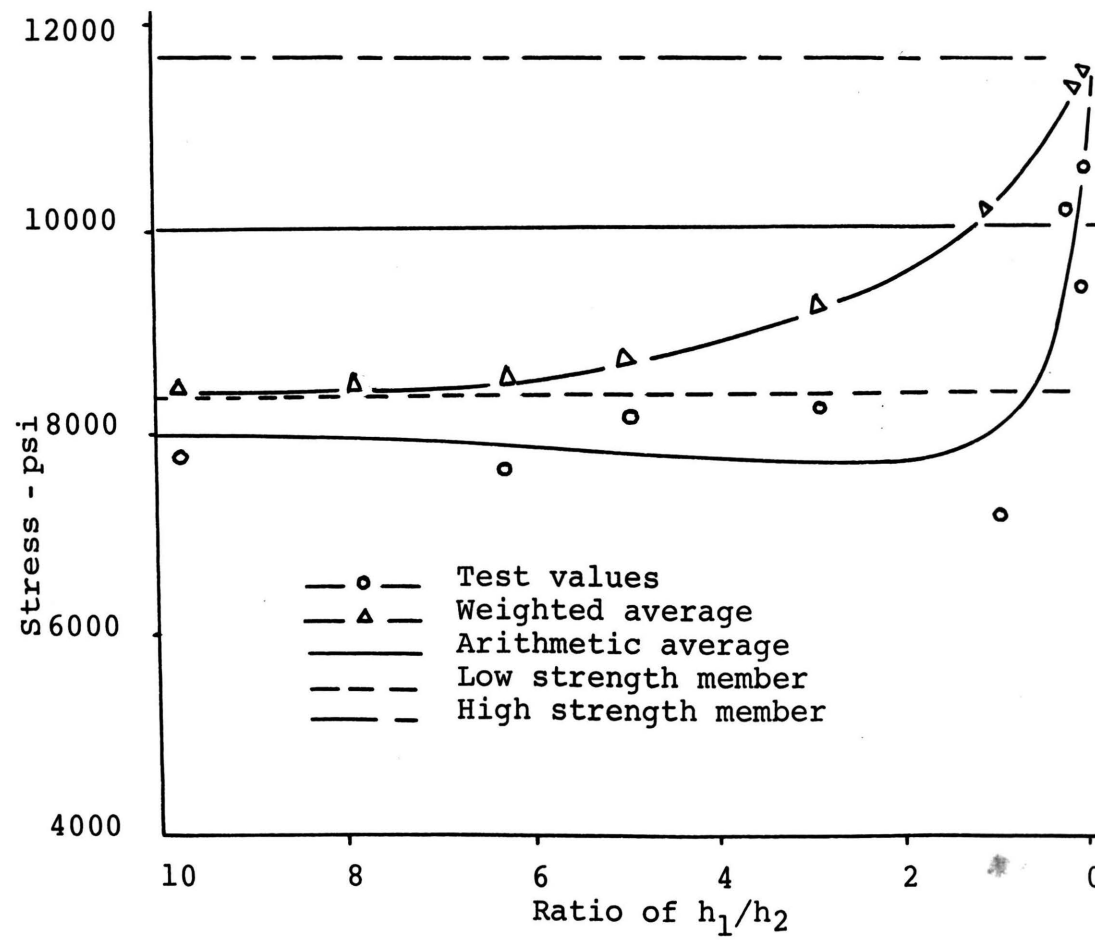

Figure 23. Compressive Strength Versus Ratio of h_1/h_2
(Sandstone/Dolomite)

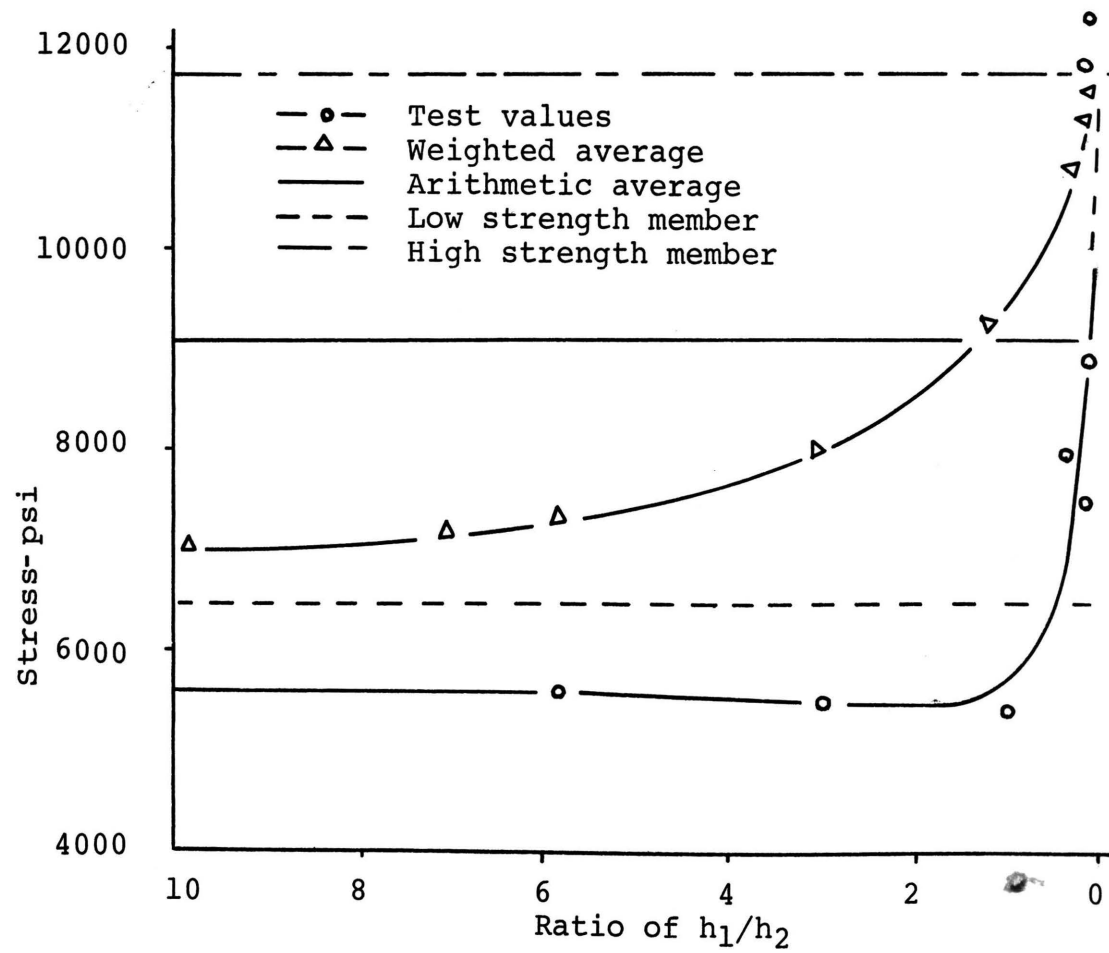

Figure 24. Compressive Strength Versus Ratio of h_1/h_2
(Limestone/Dolomite)

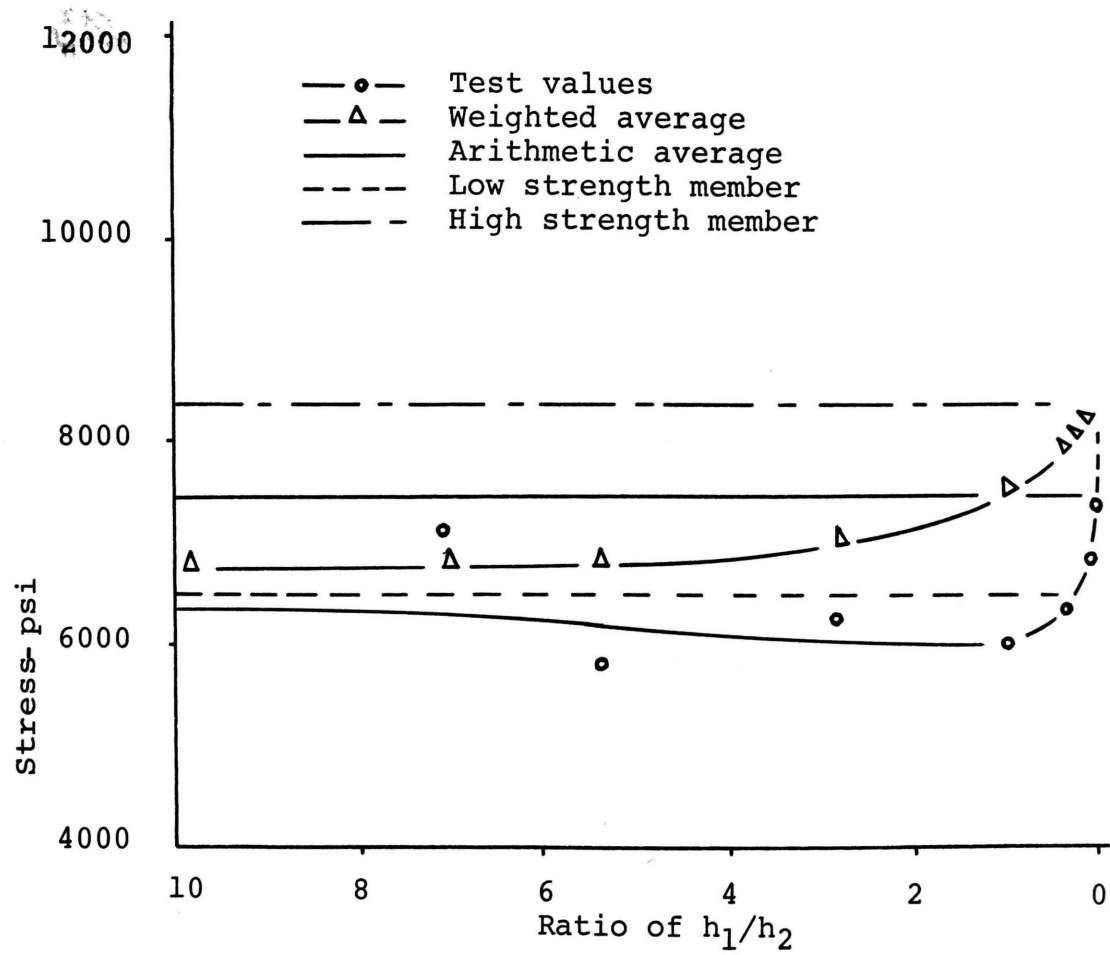

Figure 25. Compressive Strength Versus Ratio of h_1/h_2
(Limestone/Sandstone)

rapidly as seen in Figure 26. The difference between the weighted average and test values becomes constant when the proportion of weak strength member is increased. In general the difference between the weighted average and test values increases as the difference between the strengths of the two strata increases.

The difference between the arithmetic average and the compressive strength of a layered specimen is approximately constant until the height of the weak strength member is approximately equal to the height of the high strength member. As the thickness of the high strength member is increased further, the difference decreases and ultimately exceeds the arithmetic average. The proportion of the heights of the members at which the test values exceed the arithmetic average depends on the strength ratios, Figure 27. The difference between the arithmetic average and test values increases as the strength ratios increase.

C. Variation of Uniaxial Compressive Strength with a Change in Bed Thickness in Relation to the Diameter of the Pillar

The compressive strength of a layered specimen is lower than the strength of the weak member, until the thickness of weak member is equal to the diameter. When the diameter is greater than the thickness of the weak member, the compressive strength starts increasing. Higher strength ratios show higher rates of increase in compressive strength as seen in Figures 28 to 30.

The difference between the weighted average and test value is maximum when the thickness of low strength member is equal to the

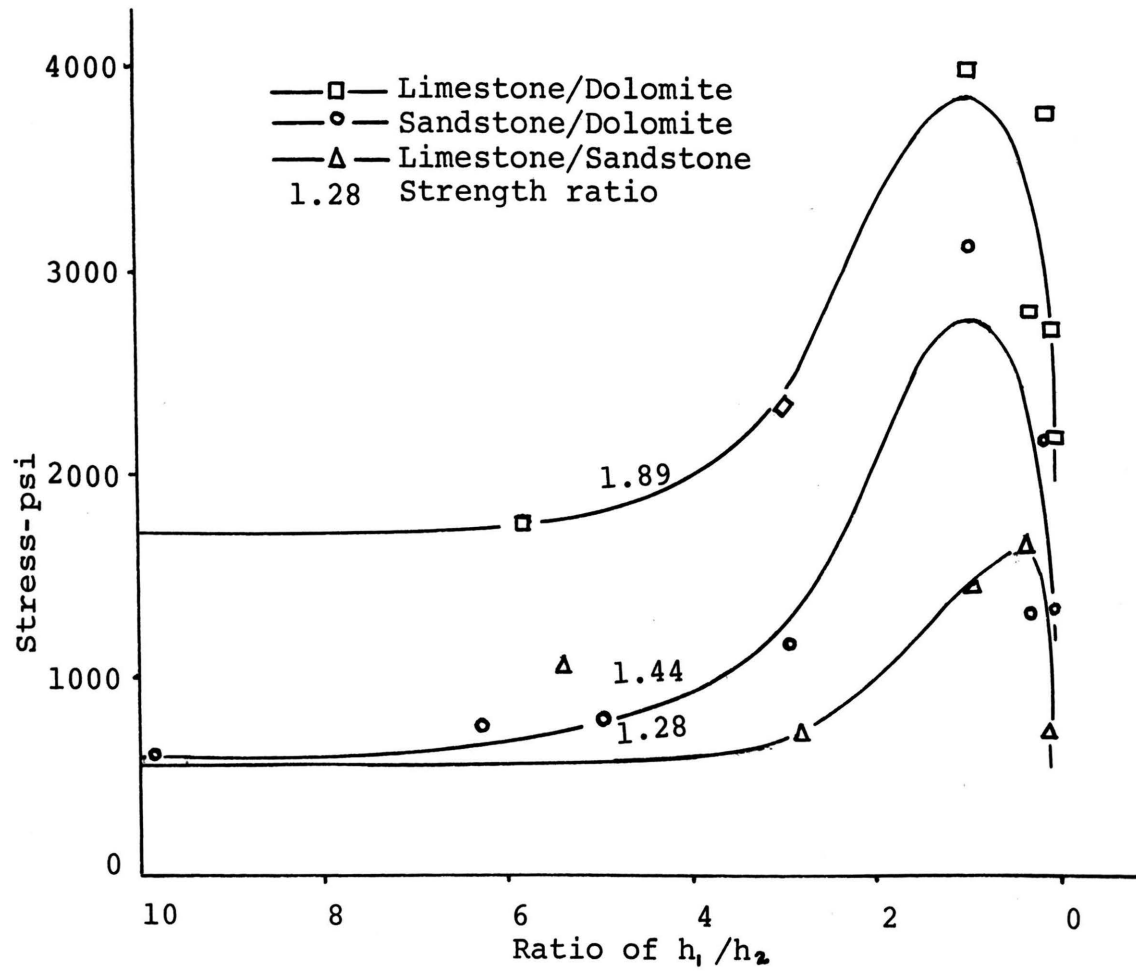

Figure 26. The Difference Between Weighted Average and Test Value Versus Ratio of h_1/h_2

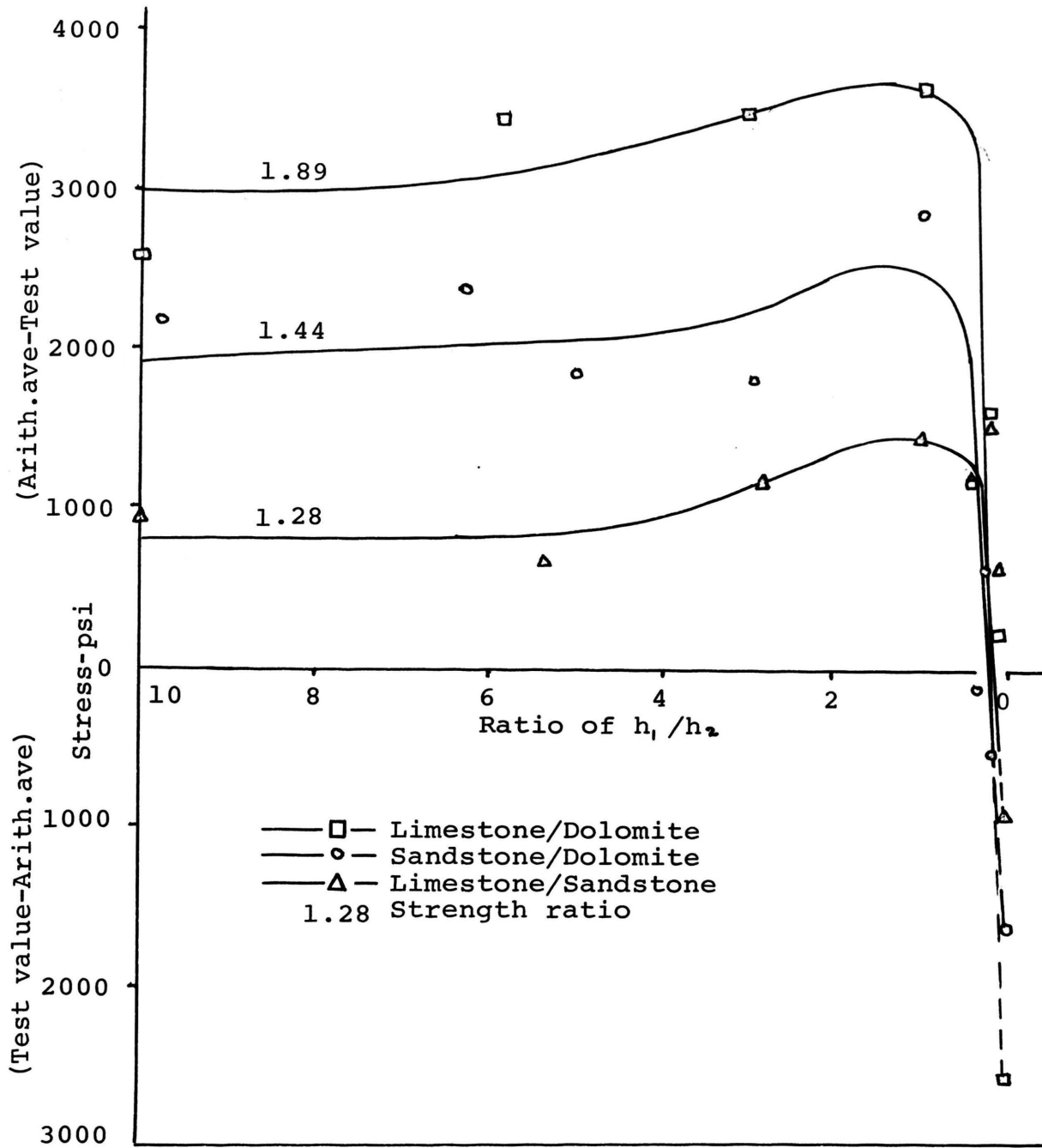

Figure 27. The Difference Between Arithmetic Average and Test Value Versus Ratio of h_1/h_2

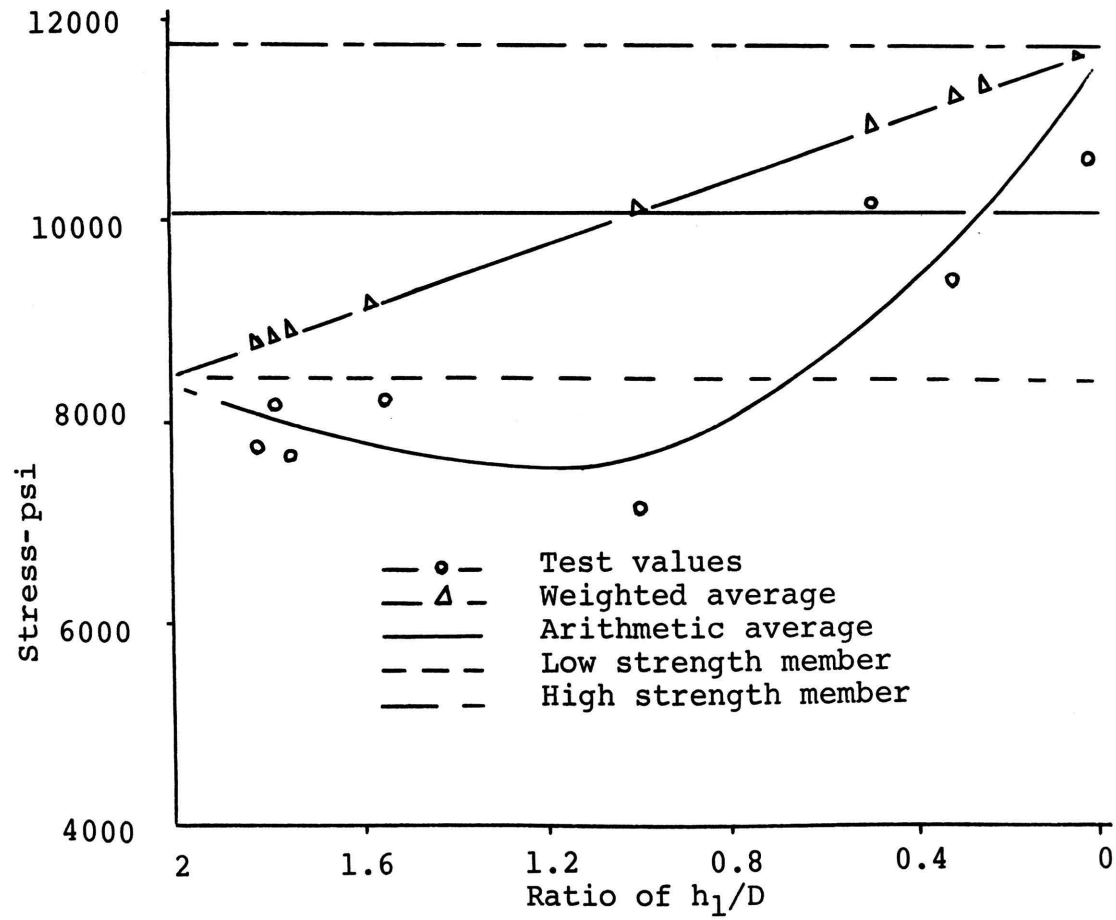

Figure 28. Compressive Strength Versus Ratio of h_1/D
(Sandstone/Dolomite)

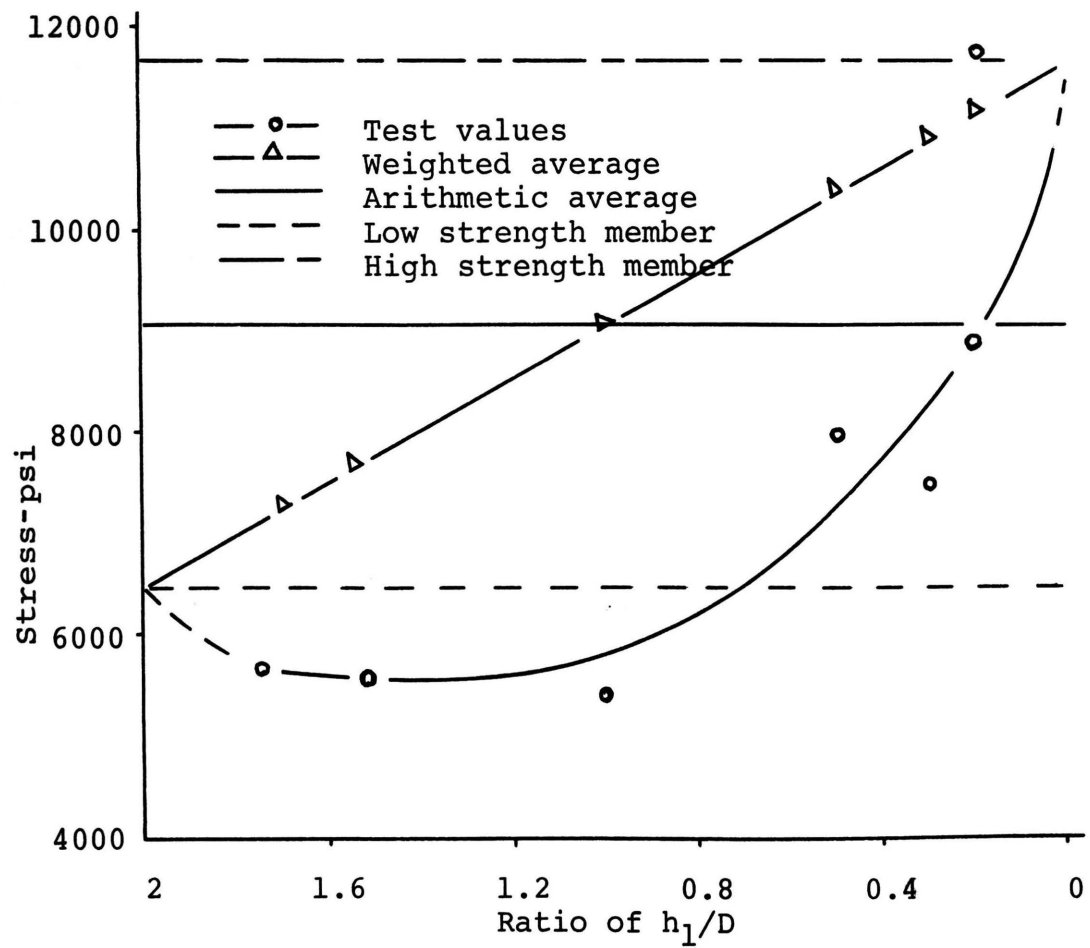

Figure 29. Compressive Strength Versus Ratio of h_1/D
(Limestone/Dolomite)

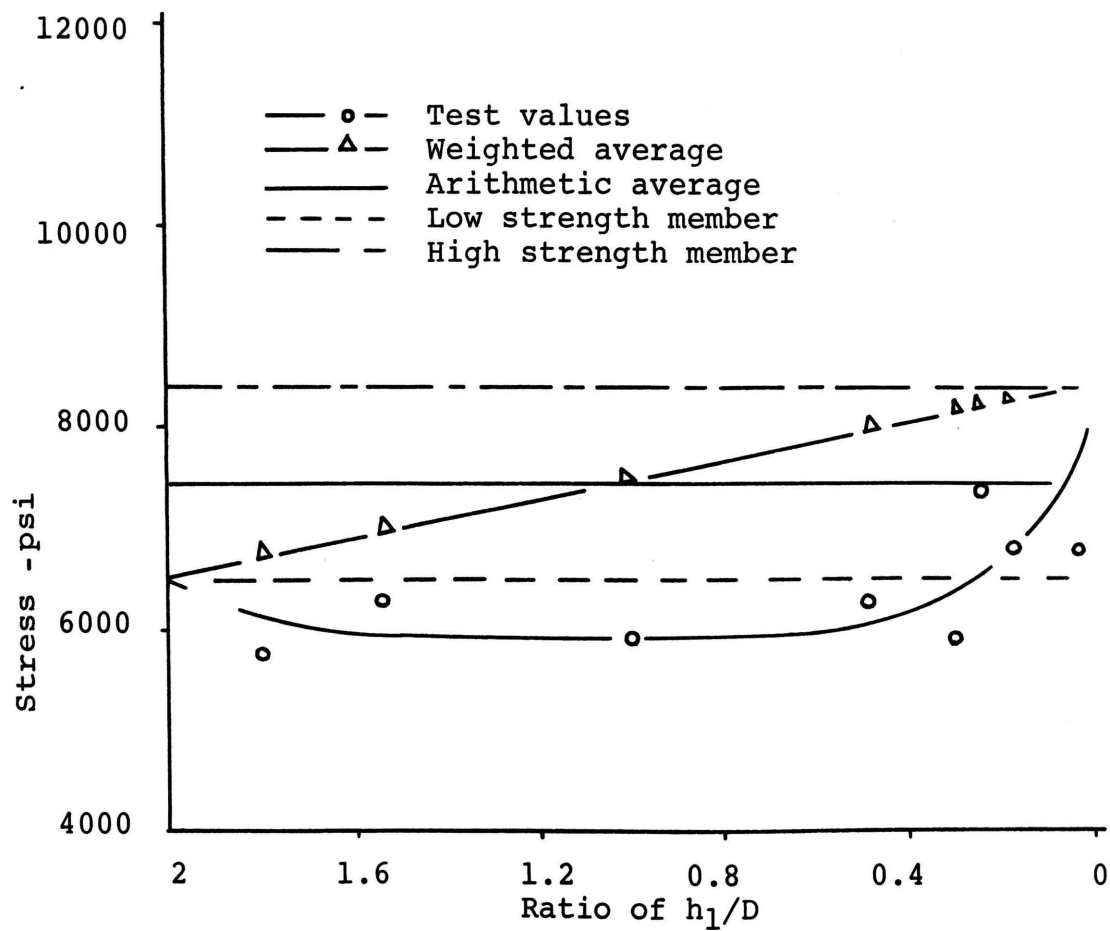

Figure 30. Compressive Strength Versus Ratio of h_1/D
(Limestone/Sandstone)

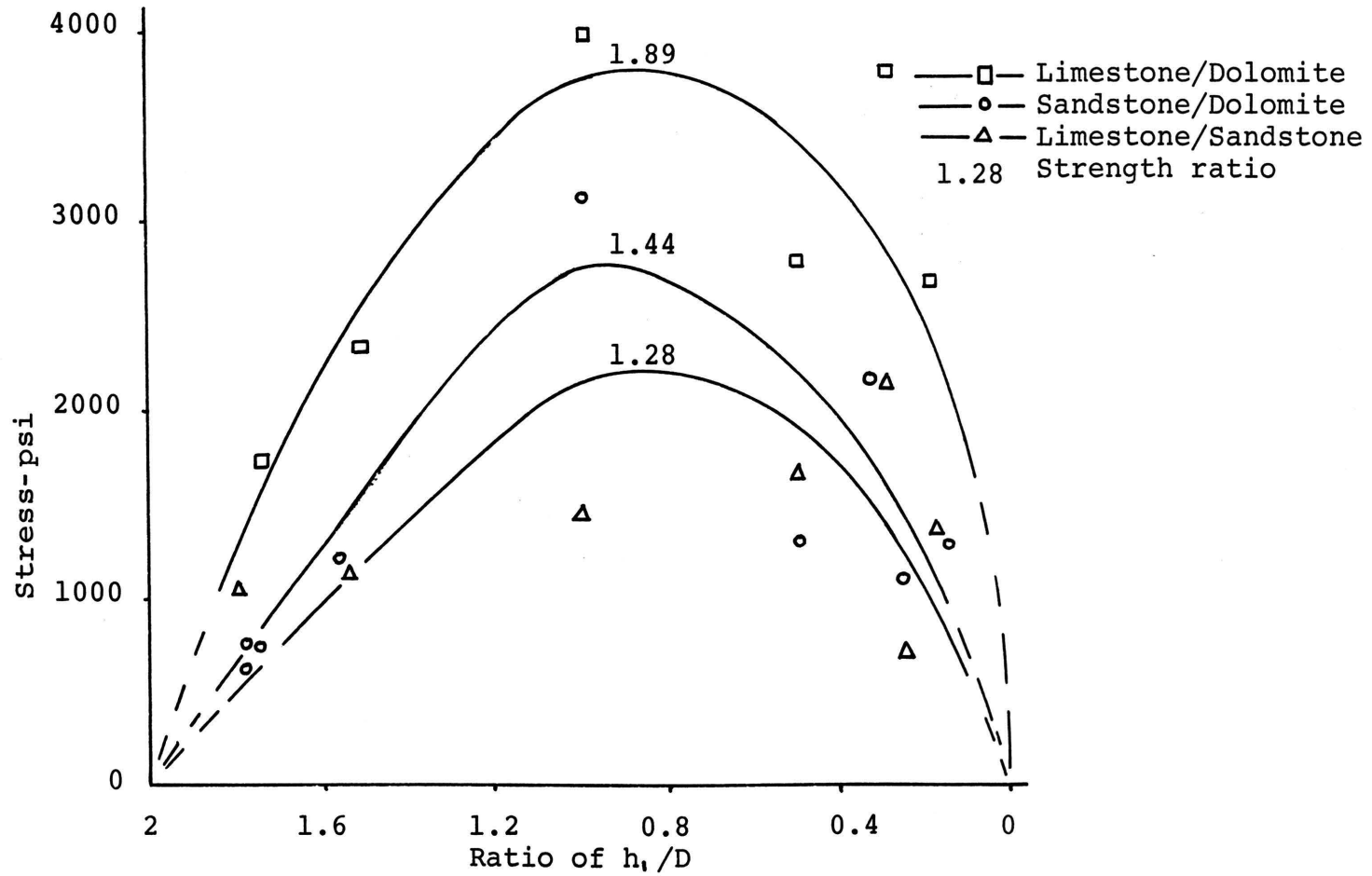

Figure 31. The Difference Between Weighted Average and Test Value Versus Ratio of h_1/D

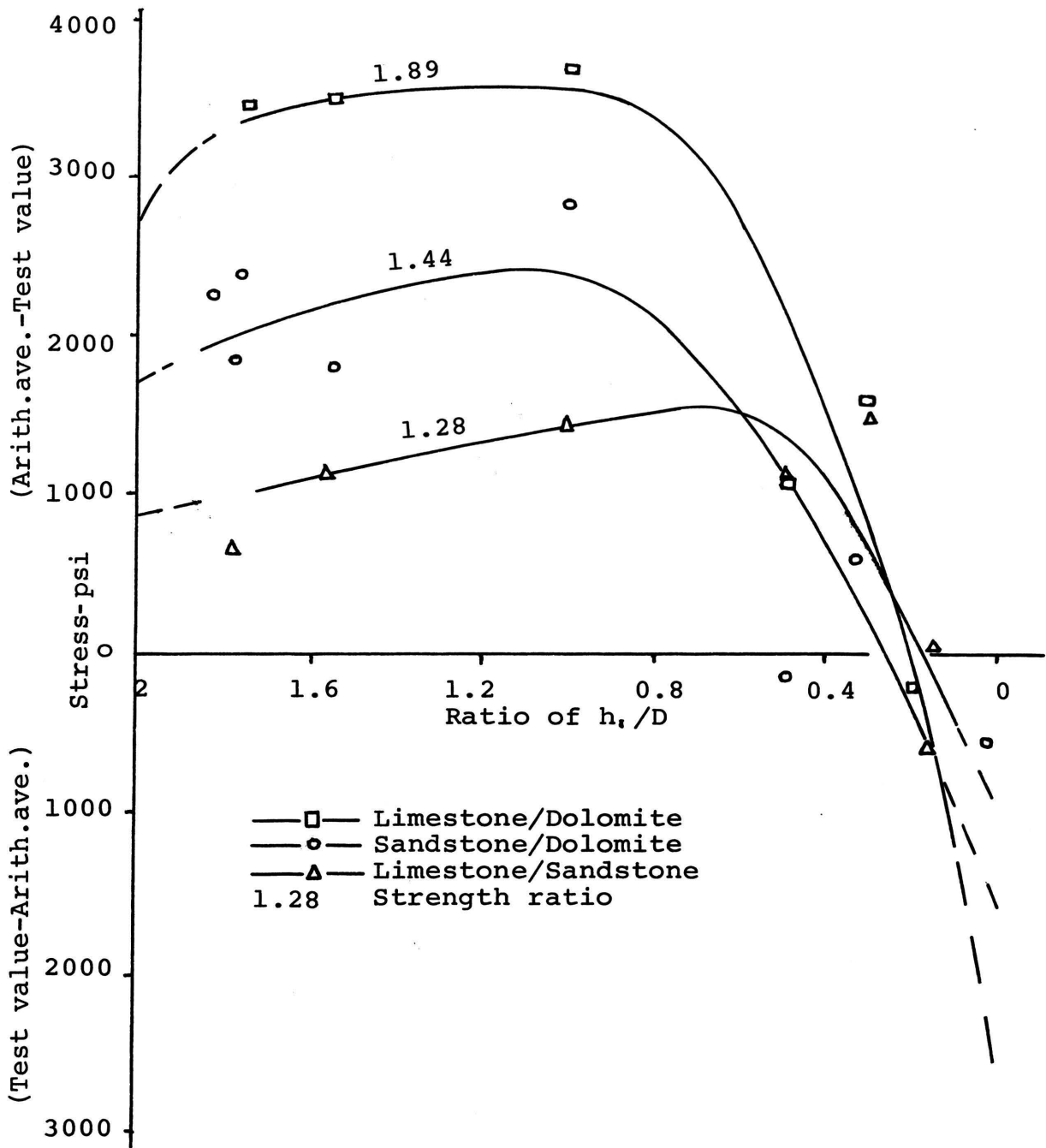

Figure 32. The Difference Between Arithmetic Average and Test Value Versus Ratio of h_1/D

diameter of the specimen. On either side of this the difference decreases, Figure 31. The difference between the weighted average and test value increases as the difference between the strengths of the members increases, Figure 31.

The test values are lower than the arithmetic average except for small thickness of the low strength member (in relation to the diameter) where they exceed the arithmetic average as seen in Figure 32.

D. Influence of Three Layers on Uniaxial Compressive Strength

Due to the limited available time only a few specimens with three layers were tested. The variation of compressive strength with a change in the thickness of each layer and its correlation to weighted and arithmetic averages and the strength of the weak strength member is shown in Table 4.

The uniaxial compressive strength (test value) shows a gradual decrease with a decrease in weighted average as seen in Table 4. The difference between the test value and weighted average shows little variation.

The difference between the arithmetic average and test value shows a greater variation. At higher strengths the difference is low and at lower strengths the difference is high. The test values are coming close to the arithmetic average where the specimen is composed more of high strength material.

FORMATION	s : l : d		s : l : d		s : l : d			s : l : d		
RATIO	1	.44	1	.44	1	1	1	1	1	.44
Wt. Ave. (psi)	9620		9270		9100			8320		
Ari. Ave. (psi)	8660		8660		8660			8660		
Weak Member (psi)	6500		6500		6500			6500		
Test Value (psi)	7840		7330		7120			6720		
Wt. Ave. less Test Value (psi)	1780		1940		1980			1600		
Ari. Ave. less Test Value (psi)	820		1330		1540			1940		

Table 4. Variation of Compressive Strength with a Change
in Thickness of Each Layer in psi

E. Influence of Length to Diameter Ratio on Uniaxial Compressive Strength

Tests were conducted on samples having three layers--sandstone, limestone and dolomite. The test value starts decreasing from an $L/D=2$ up to an $L/D=1.6$ (Figure 33) and then increases almost linearly up to an $L/D=0.65$. The test value is a little higher than the weighted average and arithmetic average at an $L/D=0.65$. All the test values are higher than the strength of the weak member.

F. Two Layers Versus Three Layers

In general, the test values for two-and three-layered specimens increased with an increase in the proportion of high strength material.

In two-layered specimens the test values were lower than the low strength material, until the proportion of low strength material was equal to or greater than the high strength material.

The test values for two-and three-layered specimens were lower than the weighted average.

In a two-layered specimen the test value was either lower or higher than the arithmetic average depending upon whether the proportion of low strength material was higher or lower than the high strength material. In three-layered specimens the difference between the arithmetic average and the test value increased as the proportion of high strength material was reduced.

From the above results and fracture analysis it may be concluded

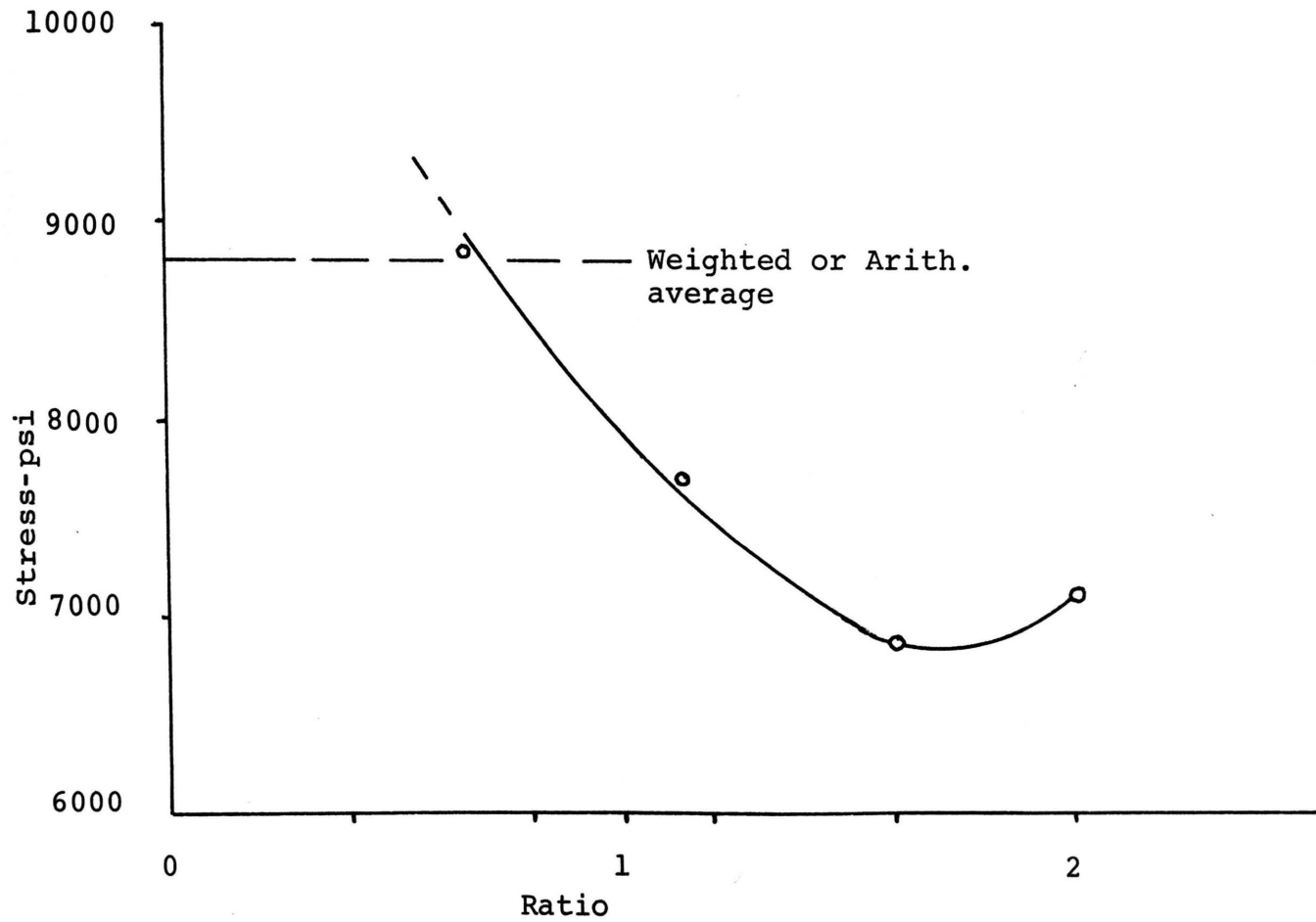

Figure 33. Compressive Strength Versus Ratio of Length to Diameter (three layers)

that the test values may have been influenced by

- 1) Fracture pattern which is partly controlled by the end conditions and geometry of the specimen
- 2) The overall effect of differential expansion at the many contact surfaces
- 3) The compressive strength of the formations on either end of the layered specimen
- 4) The effect on non-cohesive interfaces.

According to the United States Bureau of Mines¹³ the non-cohesive interfaces or horizontal weak planes will not materially effect the strength of the rock.

From an analysis of the fracture pattern it appears that the end conditions and geometry of the specimen are responsible in the formation of shear cones in these types of rocks. Different test values may have been obtained if prisms were used instead of cores.

The second condition partly depends on the first. Due to the differential expansion at the many contact surfaces, the compressive strength of a layered pillar decreases as the number of layers increase. This is evident from two-and three-layered specimens.

In multilayered specimens the formations at the ends of the specimen play an important role on the compressive strength of the specimen. As observed in the three-layered specimens, the sandstone failed with a shear cone irrespective of the thickness of limestone which was in the middle. If limestone had been placed on the top instead of sandstone, different results may have been obtained.

V. CONCLUSIONS AND RECOMMENDATIONS

A. Conclusions

Geometry and end conditions of a layered specimen have considerable influence on the failure, fracture pattern and in the resulting compressive strength.

Extremely thin layers have little effect on the overall strength of a layered specimen.

Multilayered specimens are weaker than specimens with a lesser number of layers.

Formations at the top and bottom of a layered specimen have considerable influence on the compressive strength of the specimen.

The compressive strength of a layered specimen increases as the proportion of high strength material is increased.

The compressive strength of a layered specimen is always lower than the calculated weighted average strength.

The compressive strength of a layered specimen is either lower or higher than the arithmetic average depending on the proportion of low and high strength materials.

The difference between the weighted average or arithmetic average and uniaxial compressive strength increases as the difference between

the compressive strengths of the members increases.

The uniaxial compressive strength of a layered specimen increases with a decrease in length to diameter ratio.

.. Suggestions for Design. In a two-layered pillar the compressive strength of the low strength member may be used where the proportion of low strength material is either equal to or higher than the high strength material.

When the proportion of high strength member is higher than low strength member, the weighted average may be used.

In a pillar having more than two formations, the weighted average strength may be used.

B. Recommendations

Further study is warranted in the following areas:

- 1) Further compressive strength studies on three-or more-layered specimens.
- 2) Investigation of compressive strength with a change in length-to-diameter ratio for two-layered specimens with the rocks tested in this work
- 3) Investigation of compressive strength by changing the shape of the specimen for the rocks tested in this work.

BIBLIOGRAPHY

1. American Society for Testing Materials, "Compressive Strength of Natural Building Stone," ASTM Part 11, 1942, p. 1102-1104.
2. Clausing, D. P., "Comparison of Griffith Theory and Mohr's Failure Criteria," Third Symposium on Rock Mechanics, Vol. 53, No. 3, 1959, Quarterly Colorado School of Mines.
3. Donath, F. A., and Cohen, C. I., "Anisotropy and Failure of Rocks," (Abstract), Geological Society of America Bulletin 97, 1960, p. 65-72.
4. Donath, F. A., "Experimental Study of Shear Failure in Anisotropic Rocks," Geological Society of America Bulletin, Vol. 72, June 1961, No. 6, p. 985.
5. Duvall, W. I., Obert, L., and Windes, S. L., "Standardized Tests for Determining the Physical Properties of Mine Rock," Rep. Inv. 3891, U. S. Bureau of Mines, 1946.
6. Fairhurst, C., "Laboratory Measurement of Some Physical Properties of Rock," Fourth Symposium on Rock Mechanics, Pennsylvania State University, No. 76, November 1961, p. 105-118.

7. Filon, L. N. G., "On the Elastic Equilibrium of Circular Cylinders under Certain Practical Systems of Load," Phil. Transactions, Series A, Vol. 798, 1900, p. 147.
8. Griggs, D. T., "Deformation of Rocks under High Confining Pressures," Journal of Geology, Vol. 44, 1936, p. 541.
9. Hardy, H. R., "Standardized Procedures for the Determination of the Physical Properties of Mine Rock under Short-period Uniaxial Compression," Report No. FRL-242, Department Mines and Technical Surveys, Ottawa, 1957, p. 108.
10. Jaeger, J. C., "Shear Failure of Anisotropic Rocks," Geological Magazine, Vol. 97, 1960, p. 65-72.
11. Jenkins, J. D., Discussion of article by T. Seldernrath in "Mechanical Properties of Non-Metallic Brittle Materials," Interscience Publishers, 1958.
12. Joseph, C. C., "An Investigation of the Stress Distribution in a Circular Cylinder under Static Compressive Load for Varying Boundary Conditions," M. S. Thesis, 1963, Pennsylvania State University.
13. Obert, L. Duvall, W. I., and Merrill, R. H., "Design of Underground Openings in Competent Rock," U. S. Bureau of Mines Bulletin 587, 1960.
14. Pickett, G., "Application of the Fourier Method to the Solution of Certain Boundary Problems in the Theory of Elasti-

city," Journal of Applied Mechanics, September 1944,
p. A176.

15. Silverman, I. K., "Behavior of Materials and Theories of Failure,"
Second Annual Symposium on Rock Mechanics, Quarterly of
the Colorado School of Mines, Vol. 52, No. 5, July 1957,
p. 3-18.
16. Troxell, G. E., "The Effect of Capping Methods and End Conditions
before Capping upon the Compressive Strength of Concrete
Test Cylinders," Proceedings American Society Testing
Material, Vol. 41, 1941, p. 1038.
17. Werner, G., "The Effect of Type of Capping Material on the Com-
pressive Strength of Concrete Cylinders," Proceedings
American Society Testing Materials, Vol. 58, 1958, p.
1166.

APPENDIX

EXPERIMENTAL DATA

	<u>Page</u>
Test Data for Stress-Strain Curves	56
Physical Properties of Rock Types	59
Data for Dynamic Young's Modulus	60
Data for Brazillian Tests	61
Length of Two-Layered Samples and Their Uniaxial Compressive Strength	62
Length of Three-Layered Samples and Their Uniaxial Compres- sive Strength	64
Thickness of Each Layer in Various Combinations	65

Test Data for Stress-Strain Curves

INDIANA LIMESTONE

LOAD	STRESS	STRAIN (Loading)	STRAIN (Unloading)
lbs	psi	μ in/in	μ in/in
0	0	0	36
500	241	51	89
1000	482	105	144
1500	723	159	197
2000	965	212	250
2500	1206	266	302
3000	1447	318	353
3500	1688	373	403
4000	1929	423	451
4500	2170	477	499
5000	2411	531	547
5500	2652	586	597
6000	2893	640	$\frac{1}{2}$ min. -34
			1 min. -34

KASOTA DOLOMITE

LOAD	STRESS	STRAIN (Loading)	STRAIN (Unloading)
lbs	psi	μ in/in	μ in/in
0	0	0	46
1000	482	82	135
2000	965	153	211
3000	1447	224	284
4000	1929	293	353
5000	2411	364	421
6000	2893	430	487
7000	3375	505	550
8000	3857	578	615
9000	4339	650	677
10000	4821	720	736
11000	5303	796	$\frac{1}{2}$ min. -44
			1 min. -43

BEREA SANDSTONE

LOAD	STRESS	STRAIN (Loading)	STRAIN (Unloading)
lbs	psi	μ in/in	μ in/in
0	0	0	263
500	241	114	420
1000	482	258	583
1500	723	413	735
2000	965	560	866
3000	1447	823	1145
4000	1929	1120	1348
5000	2411	1338	1505
6000	2893	1545	1642
7000	3375	1730	1780
8000	3857	1920	$\frac{1}{2}$ min. -253
			1 min. -248
			3 min. -242

Physical Properties of Rock Types

SPECIMEN No.	L/D RATIO	ULTIMATE LOAD lbs	COMPRESSIVE STRENGTH psi	YOUNG'S MODULUS psi
s ₁	2			1.66x10 ⁶
s ₂	2	17300	8340	
s ₃	2	17400	8400	
l ₁	2			4.5x10 ⁶
l ₂	2	13500	6500	
l ₃	2	13600	6550	
d ₁	2			6.95x10 ⁶
d ₂	2	26000	12500	
d ₃	2	24600	11850	

DATA FOR DYNAMIC YOUNG'S MODULUS

ROCK SPECIMEN	C_{rod} μ sec/ft	DIAMETER in	THICKNESS in	VOLUME in^3	WEIGHT grms	DENSITY #/in ³	YOUNG'S MODULUS psi
Sandstone	110	1.635	1.11	2.33	82.388	0.0777	1.66×10^6
Limestone	72	1.631	1.175	2.46	89.666	0.0804	4.02×10^6
Dolomite	60	1.644	1.116	2.37	95.775	0.0891	6.4×10^6

DATA FOR BRAZILLIAN TESTS

SPECIMEN	LENGTH in	LOAD lbs	TENSILE STRENGTH psi
s ₁₈	1.10	850	302
s ₂₆	1.00	950	372
s ₁₆	1.05	1100	410
l ₂₄	0.95	1050	430
l ₂₅	0.85	1000	460
d ₁₀	1.15	2000	680
d ₉	1.66	2400	565

LENGTH OF TWO-LAYERED SAMPLES AND THEIR
UNIAXIAL COMPRESSIVE STRENGTH

COMBINATION		TOTAL LENGTH in	ULTIMATE LOAD lbs	ULTIMATE STRESS psi
1 ₄	s ₄	3.375	12,400	6000
1 ₂₃	s ₂₄	3.420	13,000	6300
1 ₂₂	s ₁₁	3.390	12,250	5950
1 ₃₇	s ₂₇	3.250	15,350	7400
1 ₄₁	s ₃₀	3.280	14,100	6830
1 ₄₄	s ₄₃	3.200	14,000	6800
1 ₁₆	s ₇	3.270	13,000	6300
1 ₂₀	s ₁₃	3.440	12,050	5800
1 ₂₇	s ₃₉	3.250	14,800	7150
1 ₂₉	s ₄₂	3.250	17,250	8350
1 ₆	d ₈	3.350	11,150	5400
1 ₁₇	d ₁₄	3.265	16,600	8000
1 ₂₁	d ₁₈	3.410	15,550	7500
1 ₃₈	d ₂₇	3.200	24,400	11800
1 ₃₉	d ₂₆	3.290	18,400	8900
1 ₄₃	d ₄₂	3.220	25,800	12300
1 ₁₅	d ₁₆	3.285	11,600	5600
1 ₁₉	d ₂₀	3.350	11,700	5650
1 ₂₈	d ₃₆	3.250	16,200	7850
1 ₂₆	d ₃₉	3.250	16,800	8100

COMBINATION		TOTAL LENGTH in	ULTIMATE LOAD lbs	ULTIMATE STRESS psi
s ₁₀	d ₆	3.300	15,850	7180
s ₈	d ₁₅	3.310	21,250	10200
s ₁₄	d ₁₇	3.390	19,500	9450
s ₃₈	d ₂₅	3.260	26,550	12800
s ₄₁	d ₂₈	3.250	22,050	10600
s ₂₃	d ₂₄	3.360	17,000	8250
s ₁₂	d ₁₉	3.480	16,900	8200
s ₂₈	d ₃₇	3.320	15,750	7650
s ₂₉	d ₄₀	3.260	16,100	7800

LENGTH OF THREE-LAYERED SAMPLES AND THEIR
UNIAXIAL COMPRESSIVE STRENGTH

COMBINATIONS			TOTAL LENGTH in	ULTIMATE LOAD lbs	ULTIMATE STRESS psi
s ₃₄	1 ₃₂	d ₃₂	3.42	14,750	7120
s ₃₇	1 ₃₁	d ₃₁	3.45	15,150	7330
s ₃₃	1 ₃₀	d ₃₄	3.46	14,050	6760
s ₃₂	1 ₃₄	d ₂₉	3.30	16,200	7840
s ₃₁	1 ₃₆	d ₃₀	3.38	14,750	7120
s ₃₅	1 ₃₃	d ₃₃	2.62	14,150	6850
s ₃₆	1 ₃₅	d ₃₅	1.84	15,950	7700
s ₄₀	1 ₄₀	d ₃₈	1.05	18,300	8850

THICKNESS OF EACH LAYER IN VARIOUS COMBINATIONS

SPECIMEN No.	HEIGHT in	SPECIMEN No.	HEIGHT in
1 ₁	3.320	1 ₂₂	0.490
1 ₂	3.300	1 ₂₃	0.820
1 ₃	3.300	1 ₂₄	0.950
1 ₄	1.675	1 ₂₅	0.850
1 ₅	1.610	1 ₂₆	2.950
1 ₆	1.700	1 ₂₇	2.850
1 ₇	1.650	1 ₂₈	2.850
1 ₈	1.640	1 ₂₉	2.950
1 ₉	1.680	1 ₃₀	1.470
1 ₁₀	1.100	1 ₃₁	1.400
1 ₁₁	1.110	1 ₃₂	1.100
1 ₁₂	1.070	1 ₃₃	0.850
1 ₁₃	1.175	1 ₃₄	0.600
1 ₁₄	1.050	1 ₃₅	0.600
1 ₁₅	2.470	1 ₃₁	0.410
1 ₁₆	2.420	1 ₃₇	0.400
1 ₁₇	0.825	1 ₃₈	0.350
1 ₁₈	0.820	1 ₃₉	0.330
1 ₁₉	2.860	1 ₄₀	0.350
1 ₂₀	2.900	1 ₄₁	0.330
1 ₂₁	0.510	1 ₄₂	3.25
		1 ₄₃	0.12
		1 ₄₄	0.12

SPECIMEN No.	HEIGHT in	SPECIMEN No.	HEIGHT in
s ₁	3.232	s ₂₂	1.000
s ₂	3.300	s ₂₃	2.510
s ₃	3.410	s ₂₄	2.600
s ₄	1.700	s ₂₅	1.625
s ₅	1.700	s ₂₆	1.000
s ₆	1.650	s ₂₇	2.850
s ₇	0.850	s ₂₈	2.870
s ₈	0.810	s ₂₉	2.960
s ₉	1.670	s ₃₀	2.950
s ₁₀	1.610	s ₃₁	1.500
s ₁₁	2.900	s ₃₂	1.350
s ₁₂	2.900	s ₃₃	1.370
s ₁₃	0.540	s ₃₄	1.150
s ₁₄	0.540	s ₃₅	0.870
s ₁₅	1.150	s ₃₆	0.600
s ₁₆	1.050	s ₃₇	0.600
s ₁₇	1.050	s ₃₈	0.410
s ₁₈	1.100	s ₃₉	0.400
s ₁₉	1.100	s ₄₀	0.350
s ₂₀	1.100	s ₄₁	0.300
s ₂₁	1.150	s ₄₂	0.300
		s ₄₃	3.080
		s ₄₄	3.250

SPECIMEN No.	HEIGHT in	SPECIMEN No.	HEIGHT in
d ₁	3.250	d ₂₂	1.150
d ₂	3.250	d ₂₃	1.100
d ₃	3.250	d ₂₄	0.850
d ₄	1.630	d ₂₅	2.850
d ₅	1.630	d ₂₆	2.960
d ₆	1.690	d ₂₇	2.850
d ₇	1.700	d ₂₈	2.950
d ₈	1.650	d ₂₉	1.350
d ₉	1.660	d ₃₀	1.470
d ₁₀	1.150	d ₃₁	1.450
d ₁₁	1.150	d ₃₂	1.170
d ₁₂	1.116	d ₃₃	0.900
d ₁₃	1.030	d ₃₄	0.620
d ₁₄	2.440	d ₃₅	0.640
d ₁₅	2.500	d ₃₆	0.400
d ₁₆	0.815	d ₃₇	0.450
d ₁₇	2.850	d ₃₈	0.350
d ₁₈	2.900	d ₃₉	0.300
d ₁₉	0.580	d ₄₀	0.300
d ₂₀	0.490	d ₄₁	3.270
d ₂₁	1.150	d ₄₂	3.100

VITA

The author was born June 10, 1938, in Nayudugudem, A. P. State, India. He received his high school education at Board High School, Pedapadu, A. P. State. In 1954 he enrolled in the M. R. College, Vizayanagram, A. P. State, majoring in Geology. He received his B. Sc. degree in Geology in June, 1956. He enrolled in the Geology Department of the Andhra University, as a graduate student in Applied Geology. In 1958 he received his M. Sc. degree. He worked in Indian Bureau of Mines upto 1962. In September, 1962, he enrolled in Wisconsin Institute of Technology majoring in Mining Engineering. He received his B. S. degree in January, 1964. In January, 1964, he enrolled in the Mining Engineering Department of the Colorado School of Mines as a graduate student. He transferred to the Mining Engineering Department in the University of Missouri at Rolla in September, 1965.

123705